

Invertor Heat Pump

Operations manual

Model: IHP13/IHP18/IHP21/IHP26/IHP36/IHP36S

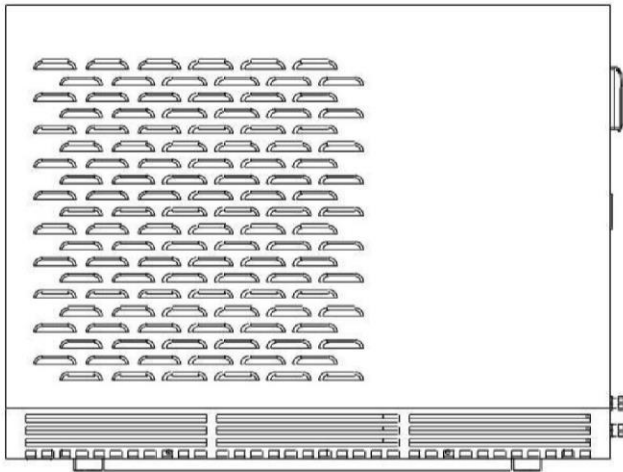

Contents

1. PRODUCT OVERVIEW

- 1.1 Specifications
- 1.2 Dimension

2. LOCATION

- 2.1 Location and Space Requirement
- 2.2 How to remove the front cover
- 2.3 Condensation Draining Hose Installation
- 2.4 Water Connection
- 2.5 Connecting the By-pass Kit
- 2.6 Typical in-ground pool arrangement
- 2.7 Electrical Connection
- 2.8 Before Starting

3. DISPLAY AND OPERATION

- 3.1 Keyboard (it might have different kind of control panel with the same keyboard functions)
- 3.2 Display of Controller
- 3.3 Structure of Interface Display
- 3.4 The Main Masks of Controller
- 3.5 Unit On/Off
- 3.6 Temperature Setting
- 3.7 Work Mode Changing (Heating/Cooling)
- 3.8 Turbo Mode Changing
- 3.9 Language setting
- 3.10 I/O Mask (figures & status checking)
- 3.11 Timezone /Clock setting
- 3.12 User Figures Setting
- 3.13 Professional Program Setting (for professional technician only)
- 3.14 Alarm Checking

4 MAINTENANCE

5 Troubleshooting

6 ALARM CODE LIST

7 DIAGRAMS

8 TERMS OF THE WARRANTY

Warnings:



The installation, disassembly and maintenance of this appliance must be done by a qualified installer. It is forbidden to make any changes to the structure of the appliance. Failure to comply with these provisions can cause damage to people, animals or things.



Disconnect the appliance from the power supply at least one minute before accessing the electrical components. Before touching the electrical components, it is however recommended to measure the voltage across the terminals to make sure it is lower than the safety voltage.



Read this manual carefully before using the appliance.



Provide a bipolar switch with a contact opening distance of at least 3 mm in the vicinity of the appliance, as required by current regulations.



Use a dedicated electric socket for this appliance. Failure to do so could cause malfunctions.



The power supply of this appliance must be grounded.



If the electric cable appears deteriorated or damaged, it must be replaced by a qualified technician.



All the drawings shown in this manual relating to electrical, hydraulic or gas installation systems must be understood to be purely illustrative. All the safety devices, auxiliary devices and the diameters of the electrical, hydraulic and gas pipes must always be checked by a professionally qualified technician, to make sure they satisfy the applicable laws and regulations.



This appliance contains fluorinated greenhouse gases: installation must be carried out by an installer | company authorized in accordance with the European regulation EU 517/2014.



PROHIBITION:



Do not touch the air outlet grill when fan motor is running.



It is forbidden to touch the electric plug with wet hands and disconnect the electric plug by pulling the cable.





-  Water or any kind of liquid is strictly forbidden to be poured into the product, or may cause electric creepage or breakdown of the product.
-  Use the proper fuse and breaker. It is forbidden to use copper or steel wires to replace the fuse or switch.
-  Do not touch the fins of the evaporative condensing battery, they can hurt your fingers.

FAILURE TO FOLLOW THESE WARNINGS MAY RESULT IN PROPERTY DAMAGE, ELECTRIC SHOCK, ENTANGLEMENT OR OTHER SERIOUS INJURY OR DEATH.

Safety Precautions(R32)



Meanings of symbols displayed on heat pump unit

- Since rotating parts and parts which could cause an electric shock are used in this product, be sure to read these "Safety Precautions" before use.









	WARNING	This unit uses a flammable refrigerant (1132). If refrigerant leaks and comes in contact with fire or heating part, it will create harmful gas and
	Read the OPERATING INSTRUCTIONS carefully before operation.	
	Service personnel are required to carefully read the OPERATING INSTRUCTIONS and INSTALLATION MANUAL before operation.	
	Further information is available in the OPERATING INSTRUCTIONS, INSTALLATION MANUAL, and the like.	





- Since the cautionary items shown here are important for safety, be sure to observe them.
- After reading this manual, keep it together with the installation manual in a handy place for easy reference.
- Be sure to receive a guarantee card from your dealer and check that the purchased data and shop name, etc. are entered correctly.



Marks and their meanings

	WARNING	Incorrect handling could cause serious hazard, such as death, serious injury, etc. with a high probability.
	CAUTION	Incorrect handling could cause serious hazard depending on the conditions.

Meanings of symbols used in this manual

	Be sure not to do.
	Be sure to follow the instruction.
	Never insert your finger or stick, etc.
	Never step into the indoor/outdoor unit and do not put anything on them.
	Danger of electric shock. Be careful.
	Be sure to disconnect the power supply plug from the power outlet.
	Be sure to shut off the power.
	Risk of fire.



	<p>Do not connect the power cord to an intermediate point, use an extension cord, or connect multiple devices to heat pump.</p> <ul style="list-style-type: none"> - This may cause overheating, fire or electric shock.
	<p>Make sure the power plug is free of dirt and insert it securely into the outlet.</p> <ul style="list-style-type: none"> - A dirty plug may cause fire or electric shock.
	<p>Do not bundle, pull, damage, or modify the power cord, and do not apply heat or place heavy objects on it.</p> <ul style="list-style-type: none"> - This may cause fire or electric shock.
	<p>Do not turn the breaker OFF/ON or disconnect/connect the power plug during operation.</p> <ul style="list-style-type: none"> - This may create sparks, which can cause fire.
	<p>Do not expose your body directly to cool air for a prolonged length of time.</p> <ul style="list-style-type: none"> - This could be detrimental to your health.
	<p>The unit should not be installed, relocated, disassembled, altered, or repaired by the user.</p> <ul style="list-style-type: none"> - An improperly handled heat pump may cause fire, electric shock, injury, or water leakage, etc. Consult your dealer. - If the power supply cord is damaged, it must be replaced by the manufacturer or its service agent in order to avoid a hazard.
	<p>When installing, relocating, or servicing the unit, make sure that no substance other than the specified refrigerant (R32) enters the refrigerant circuit.</p> <ul style="list-style-type: none"> - Any presence of foreign substance such as air can cause abnormal pressure rise and may result in explosion or injury. - The use of any refrigerant other than that specified for the system will cause mechanical failure, system malfunction, or unit breakdown. <p>In the worst case, this could lead to a serious impediment to securing product safety.</p>
	<p>This appliance is not intended for use by persons (including children) with reduced physical, sensory or mental capabilities, or lack of experience and knowledge, unless they have been given supervision or instruction concerning use of the appliance by a person responsible for their safety.</p>
	<p>Children should be supervised to ensure that they do not play with the appliance.</p>
	<p>The appliance shall be stored in a room without continuously operating ignition sources (for example: open flames, an operating gas appliance or an operating electric heater).</p>
 	<p>Do not insert your finger, a stick, or other objects into the air inlet or outlet.</p> <ul style="list-style-type: none"> - This may cause injury, since the fan inside rotates at high speeds during operation.
 	<p>In case of an abnormal condition (such as a burning smell), stop the heat pump and disconnect the power plug or turn the breaker OFF.</p>

	<ul style="list-style-type: none"> - A continued operation in the abnormal state may cause a malfunction, fire, or electric shock. In this case, consult your dealer.
 	<p>When the heat pump does not cool or heat, there is a possibility of refrigerant leakage. If any refrigerant leakage is found, stop operations and ventilate the room well and consult your dealer immediately. If a repair involves recharging the unit with refrigerant, ask the service technician for details.</p> <ul style="list-style-type: none"> - The refrigerant used in the heat pump is not harmful. Normally, it does not leak. However, if refrigerant leaks and comes in contact with fire or heating part of such a fan heater, kerosene heater, or cooking stove, it will create harmful gas and there is risk of fire.
	<p>The user should never attempt to wash the inside of the indoor unit. Should the inside of the unit require cleaning, contact your dealer.</p> <ul style="list-style-type: none"> - Unsuitable detergent may cause damage to plastic material inside the unit, which may result in water leakage. Should detergent come in contact with electrical parts or the motor, it will result in a malfunction, smoke, or fire. - The appliance shall be stored in a room without continuously operating ignition sources (for example: open flames, an operating gas appliance or an operating electric heater). - Be aware that refrigerants may not contain an odor. - Do not use means to accelerate the defrosting process or to clean the appliance, other than those recommended by the manufacturer. - Do not pierce or burn.
	<p>This unit should be installed outdoor or in rooms which exceed the floor space specified below. GL50: 2.2 m² or larger GL60: 2.3 m² or larger GL71180: 3.1 m² or larger</p>

Caution

	<p>Do not touch the air inlet or the aluminium fins of the heat pump unit.</p> <ul style="list-style-type: none"> - This may cause injury.
	<p>Do not use insecticides or flammable sprays on the unit.</p> <ul style="list-style-type: none"> - This may cause a fire or deformation of the unit.
	<p>Do not expose pets or houseplants to direct airflow.</p> <ul style="list-style-type: none"> - This may cause injury to the pets or plants.
	<p>Do not place other electric appliances or furniture under the heat pump unit.</p> <ul style="list-style-type: none"> - Water may drip down from the unit, which may cause damage or malfunction.
	<p>Do not leave the unit on a damaged installation stand.</p> <ul style="list-style-type: none"> - The unit may fall and cause injury.
	<p>Do not step on an unstable bench to operate or clean the unit.</p> <ul style="list-style-type: none"> - This may cause injury if you fall down.
	<p>Do not pull the power cord.</p> <ul style="list-style-type: none"> - This may cause a portion of the core wire to break, which may cause overheating or fire.
	<p>Do not charge or disassemble the batteries, and do not throw them into a fire.</p> <ul style="list-style-type: none"> - This may cause the batteries to leak, or cause a fire or explosion.

	<p>Do not use the unit for special purposes, such as storing food, raising animals, growing plants, or preserving precision devices or art objects.</p> <ul style="list-style-type: none"> - This may cause deterioration of quality, or harm to animals and plants.
	<p>Do not expose combustion appliances to direct airflow.</p> <ul style="list-style-type: none"> - This may cause incomplete combustion.
	<p>Before cleaning the unit, switch it OFF and disconnect the power plug or turn the breaker OFF.</p> <ul style="list-style-type: none"> - This may cause injury, since the fan inside rotates at high speeds during operation.
	<p>When the unit will be unused for a long time, disconnect the power plug or turn the breaker OFF.</p> <ul style="list-style-type: none"> - The unit may accumulate dirt, which may cause overheating or fire.
	<p>Ensure that the area is well-ventilated when the unit is operated together with a combustion appliance.</p> <ul style="list-style-type: none"> - Inadequate ventilation may cause oxygen starvation.
	<p>After the heat pump is used for several seasons, perform inspection and maintenance in addition to normal cleaning.</p> <p>Dirt or dust in the unit may create an unpleasant odor, contribute to growth of fungi, such as mold, or clog the drain passage, and cause water to leak from the indoor unit. Consult your dealer for inspection and maintenance, which require specialized knowledge and skills.</p>



	<p>Do not operate switches with wet hands.</p> <ul style="list-style-type: none"> - This may cause electric shock.
	<p>Do not clean the heat pump with water or place an object that contains water, such as a flower vase, on it.</p> <ul style="list-style-type: none"> - This may cause fire or electric shock.
	<p>Do not step on or place any object on the unit.</p> <ul style="list-style-type: none"> - This may cause injury if you or the object falls down.







Important

Dirty filters cause condensation in the heat pump which will contribute to the growth of fungi such as mold. It is therefore recommended to filters every 2 weeks.

For Installation

Warning

	<p>Consult your dealer for installing the heat pump.</p> <ul style="list-style-type: none"> - It should not be installed by the user since installation requires specialized knowledge and skills. An improperly installed heat pump may cause water leakage, fire, or electric shock.
	<p>Provide a dedicated power supply for the heat pump.</p> <ul style="list-style-type: none"> - A non-dedicated power supply may cause overheating or fire.
	<p>Do not install the unit where flammable gas could leak.</p> <ul style="list-style-type: none"> - If gas leaks and accumulates around the unit, it may cause an explosion.
	<p>Earth the unit correctly.</p> <ul style="list-style-type: none"> - Do not connect the earth wire to a gas pipe, water pipe, lightning rod, or a telephone ground wire. Improper earthing may cause electric shock.

	<p>Install an earth leakage breaker depending on the installation location of the heat pump (such as highly humid areas).</p> <ul style="list-style-type: none"> - If an earth leakage breaker is not installed, it may cause electric shock 					
	<p>Ensure that the drain water is properly drained.</p> <ul style="list-style-type: none"> - If the drain passage is improper, water may drip down from the unit, wetting and damaging the furniture. 					
	<p>Please prepare the professional tools for R32 refrigerant heat pump before you do maintenance.</p>					
	R32 leak detector		Explosion - proof vacuum pump		Anti- static glove s	 

ATTENTION:

Please observe the following rules when installing the heat pump:

1. Any addition of chemicals must take place in the piping located downstream from the heat PUMP.
2. Always place the heat pump on a solid foundation and use the included rubber mounts to avoid vibration and noise.
3. Always hold the heat pump upright. If the unit has been held at an angle, wait at least 24 hours before starting the heat pump.

1. PRODUCT OVERVIEW

1.1 Specifications

Code	Model	Heating Capacity in A27 °C/W27 °C (kW)	COP Range	Heating Capacity in A15 °C/W26 °C (kW)	COP Range	Operating Temp.	Heating Input Power (kW)	Rated Heating Running Current (A)	Power Supply	Compressor	Noise (Min-Max) dB(A)	Water Connections (mm)	Water Flow Volume (m3/h)
31000001	IHP13	3.5-13.5	6-16	2-9.5	4.5-8	-15°C	0.22-2.2	1-10	220~230V/1Ph/50Hz	Full DC Inverter	42-50	50/48.3	4-7
31000002	IHP18	4.5-18	6-16	2.5-12	4.5-8	-15°C	0.35-3.2	1.8-15	220~230V/1Ph/50Hz	Full DC Inverter	42-50	50/48.3	5-8
31000003	IHP21	5-21	6.1-16.1	3-14.5	4.6-8.1	-15°C	0.4-3.4	1.8-15.5	220~230V/1Ph/50Hz	Full DC Inverter	42-52	50/48.3	5-8
31000004	IHP26	7-26	6-15.5	4-18	4.5-8.1	-15°C	0.5-4.3	2.3-21	220~230V/1Ph/50Hz	Full DC Inverter	43-53	50/48.3	5-8
31000005	IHP36	9-36	6-16	6-24	4.5-8	-15°C	0.75-6	3.4-27.3	220~230V/1Ph/50Hz	Full DC Inverter	46-54	50/48.3	6-10
31000006	IHP36S	9-36	6-16	6-24	4.5-8	-15°C	0.75-6	1.3-10.7	380~415V/3Ph/50Hz	Full DC Inverter	46-54	50/48.3	6-10

Code	Model	Net Weight (KG)	Gross Weight (KG)	Net Dimensions (without front cover) (mm)	Packing Dimensions (without front cover) (mm)	Net dimensions (with front cover) (mm)	Packing dimensions (with front cover) (mm)
31000001	IHP13	50	58	970*370*650	1170*415*800	970*470*650	1170*515*800
31000002	IHP18	55	63	970*370*650	1170*415*800	970*470*650	1170*515*800
31000003	IHP21	75	85	1115*430*850	1200*520*990	1115*530*850	1200*620*990
31000004	IHP26	78	85	1115*430*850	1200*520*990	1115*530*850	1200*620*990
31000005	IHP36	120	135	1115*430*1350	1200*520*1350	1115*530*1350	1200*620*1500
31000006	IHP36S	120	135	1115*430*1350	1200*520*1350	1115*530*1350	1200*620*1500

1.2 Dimension

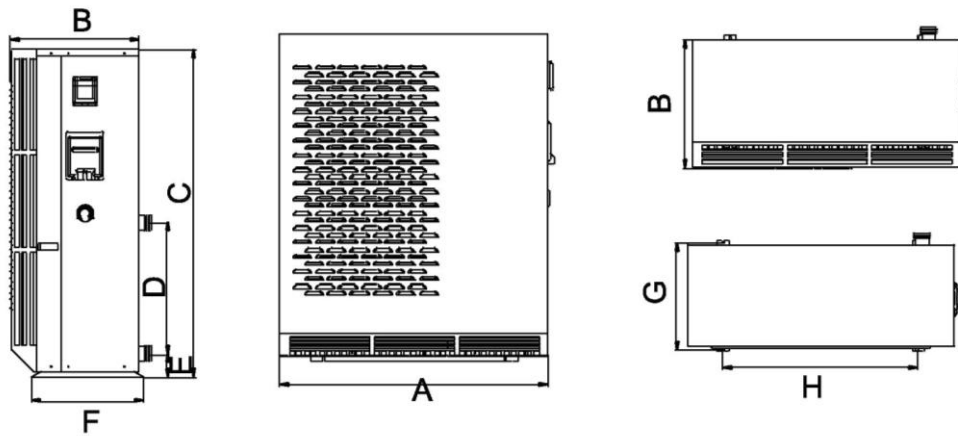

Size(mm)	A	B	C	D	E	F	G	H
IHP13/IHP18	942	477	650	305	96	400	380	700
IHP21/IHP26	1102	527	850	350	106	460	440	800
IHP36/IHP36S	1102	527	1350	540	96	460	440	800

2. LOCATION

2.1 Location and Space Requirement

- The air source heat pump must be installed outdoors. It cannot be installed indoors.

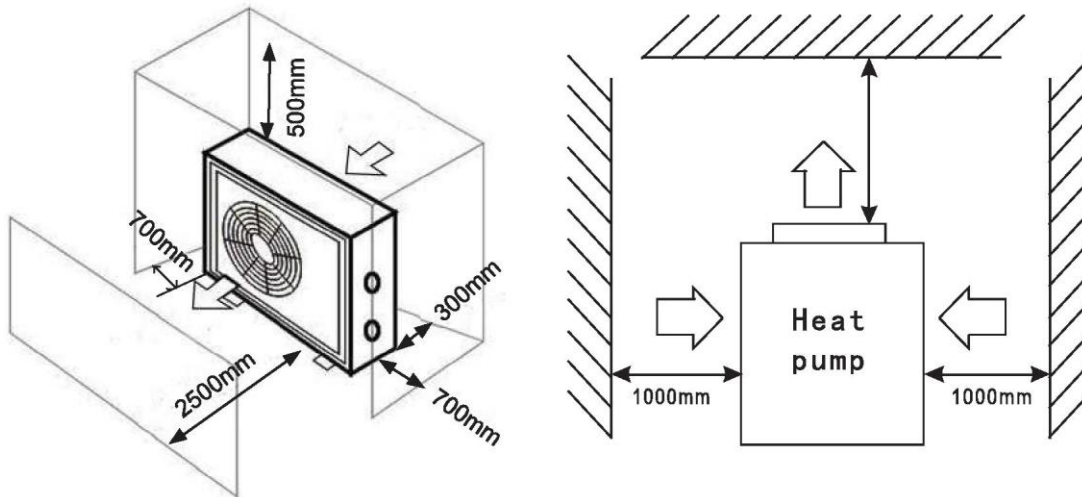

- Never install the unit in a closed room with a limited air volume in which the air expelled from the unit will be reused, or close to garden plants that could block the air inlet. Such locations impair the continuous supply of fresh air, resulting in reduced efficiency, performance and possibly preventing sufficient heat output.
- During normal operations, the heat pump evaporator fins produce condensation water. The amount of condensation produced varies according to ambient conditions. The higher the air humidity, the higher the amount of condensation produced (several liters per day). The lower heat pump panel acts as a condensation collection tray. Keep the drain hole clean.
- The heat pump must be positioned to avoid damages caused by water or condensation leaks. Install suitable drainage outlets or collection containers.
- The heat pump must be fixed and installed on a flat, solid, vibration free and level support (cement slab or prefabricated platform). Do not install the heat pump on unstable ground.
- To reduce noise wave echoes, do not install the heat pump in the immediate vicinity of vertical walls and use the included anti-vibration pads during installation.
- Make sure the pump is not subject to rain water flows from nearby building roofs. Protruding roofs without gutters could pour significant amounts of water and/or debris on the heat pump which could damage it. If necessary, install gutters or discharge outlets to protect the heat pump.
- Make sure the heat pump is not within the range of any sprinkler or irrigation systems. If necessary, install suitable protections.

2.2 How to remove the front cover

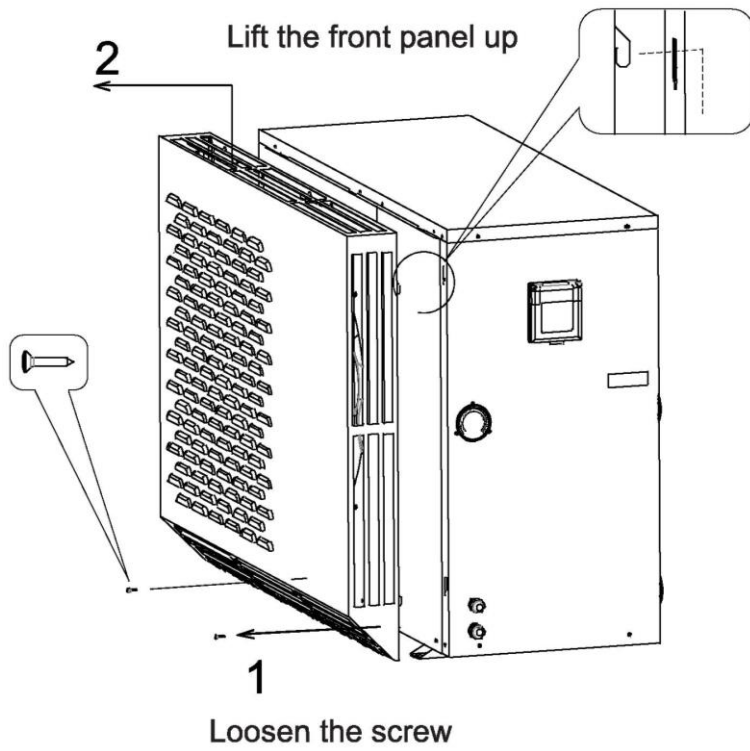
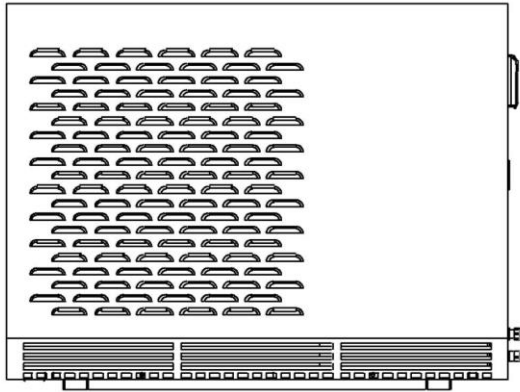

2.3 Condensation Draining Hose Installation

NOTE: The air drawn into the heat pump is strongly cooled by the operation of the heat pump for heating the pool water, which may cause condensation on the evaporator fins. The amount of condensation may be as much as several litres per hour at high relative humidity. This is sometimes mistakenly regarded as a water leak.

1. Slightly tilt the unit to reveal the bottom panel.
2. Attach the drain hose connector (9) to the bottom panel.
3. Attach the wider end of the drain hose (10) to the hose connector and place the other end into a suitable discharge area.

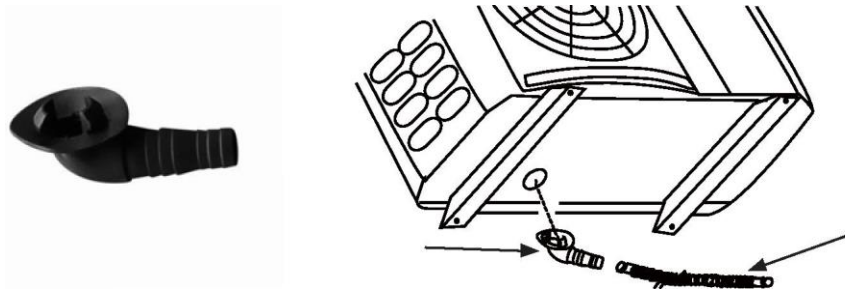

2.4 Water Connection

The following retail components (not included) are recommended for the hydraulic connections:

- Cut-off valves upstream and downstream from the heat pump to facilitate maintenance and/or heat pump bypass from the pool water circulation system.
- A non-return or check valve, installed between the pool and the heat pump outlet fitting, to prevent water reflux.

All chemical feeder or water treatment devices must be installed downstream from the heat pump and non-return (check) valve. It is important to install a check valve to prevent chemical saturated water reflux which could damage the heat pump and void the warranty.

The water circulation system must be arranged observing the following general layout:

Pool → Pump → Filter → Heat Pump → Non-return/Check Valve → Chemical Treatment → Pool

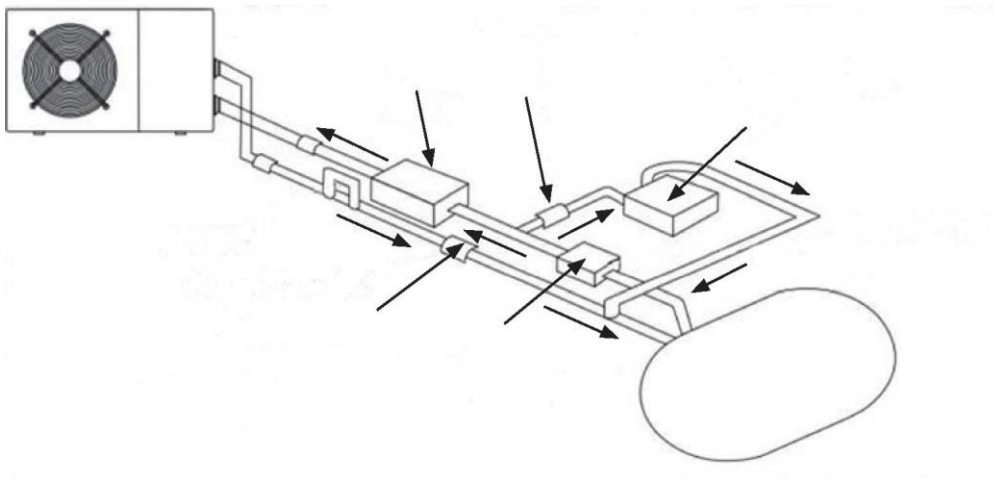

2.9 Connecting the By-pass Kit

Valve 1:
Slightly closed
(Water pressure increase with just 100 to 200gr)

Valve 2:
Completely open

Valve 3:
Half way open

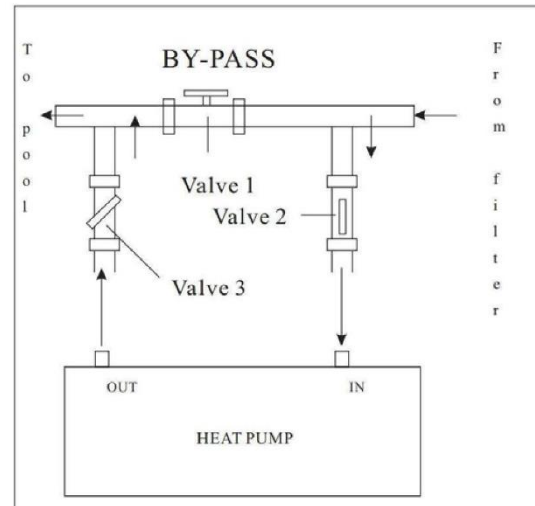

NOTE: Operation without a bypass or with improper bypass adjustment may result in sub-optimal heat pump operation and possibly damage to the heat pump, which renders the warranty null and void.

2.10 Typical in-ground pool arrangement

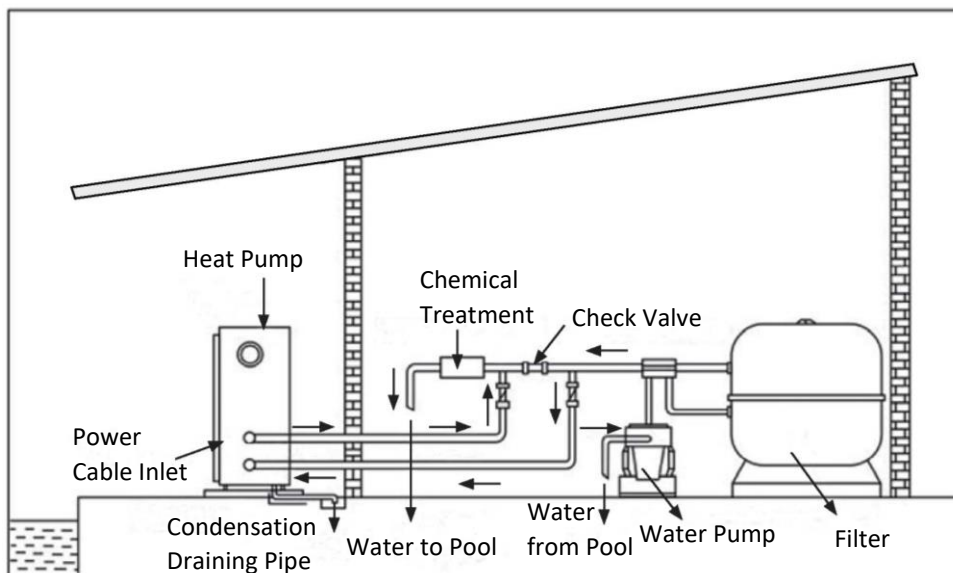

Warning:

Although the heat pump is electrically isolated from the rest of the swimming pool system, this only prevents the flow of electrical current to or from the water in the pool. Grounding the heat pump is required for protection against short-circuits inside the unit. Always provide a good grounding connection outlet. If not sure, contact a qualified electrician for assistance.

2.11 Electrical Connection



Caution:

- Use a properly sized main electrical switch.
- The power supply for the heat pump must be grounded.
- Electrical wiring must be done by a qualified technician.
- The electrical wiring must be carried out in compliance with local regulations. The electrical wiring must be done with the unit with local regulations.
- Wiring must be securely fastened.
- Do not let the wiring touch together.
- Make sure that the main power supply complies with the name plate on the unit.
- Make sure that the power, wiring and power socket comply with the power of the appliance.
- To connect the appliance to the power supply, proceed as the wiring diagram of the unit.

		<p>Cable Wiring:</p> <ol style="list-style-type: none">1. Open the wiring block box (marked white) on the side of the machine.2. Fix the other side on joints inside the electric box follow 'L', 'N', 'Earth' symbols.
		<p>Water Pump Wiring:</p> <ol style="list-style-type: none">1. Open the wiring block box (marked white) on the side of the machine.2. Fix the other side on joints inside the electric box follow 1", "2" symbols (Max 200W for this dry contact if it is connected to water pump directly).

2.12 Before Starting

Make sure the pool is filled with water to the correct level, the skimmer and suction fittings are below the water level.

To heat the pool water, the filter pump must be running to cause the water to circulate through the heat pump. The heat pump will not start up if the water is not circulating, therefore the heat pump must operate together with the filter pump.

After all the water connections have been attached and checked, carry out the following procedure:

1. Switch on the filter pump. Check for leaks and verify that water is flowing from and to the swimming pool.
2. Press the On /Off button on the control unit panel to activate it, the display shows the water inlet and outlet temperatures. The unit will start up after the time delay expires (see "**Time Delay**" section).
3. After a few minutes, check whether the air blowing out of the heat pump fan is cooler.
4. When the filter pump is turned off, the heat pump should also turn off automatically, if not, then adjust the flow switch (performed by specialist technician only).
5. Allow the heat pump and the filter pump to run 24 hours a day until the desired water temperature is reached. The heat pump will stop running at this point. After this, it will restart automatically (as long as the filter pump is running) whenever the swimming pool water temperature drops 2 degrees below the set temperature.
6. To set the water temperature and program the heat pump, see "**Display Control Panel Operation**" section for details.

Depending on the initial temperature of the pool water and the ambient air temperature, it may take several days to heat the pool water to the desired temperature. A good solar pool cover can reduce the heating time.

Time Delay

The heat pump has a built-in 1 to 2-minute start-up delay to protect the control circuit components and avoid excessive restart cycles. The unit will restart automatically after this time delay expires. Even a brief power interruption will trigger this time delay and prevent the unit from restarting immediately. Additional power interruptions during this delay period do not affect the 1 to 2-minute duration of the delay.













Water Flow Switch

The heat pump is equipped with a flow switch to protect it from running without adequate water flow rate. It will turn on when the pump runs and shut it off when the pump shuts off. If the pool water level is higher than 1m above or below the heat pump's automatic flow switch adjustment knob, your specialist technician may need to adjust the initial start-up water flow rate.

3 DISPLAY AND OPERATION

3.1 Keyboard (it might have different kind of control panel with the same keyboard functions)



No	Key	Description
1	 	Alarm: To check or clean alarm details.
2	 	Program: For advanced technician setting only(need password)
3	 	Esc: Exit
4	 	Up: Turn page up or change figure.
5	 	Enter: Enter setting or confirm setting.
6	 	Down: Turn page down or change figure.

3.2 Display of Controller

This is the main screen when the unit is power on. Parameters setting by pressing

keys

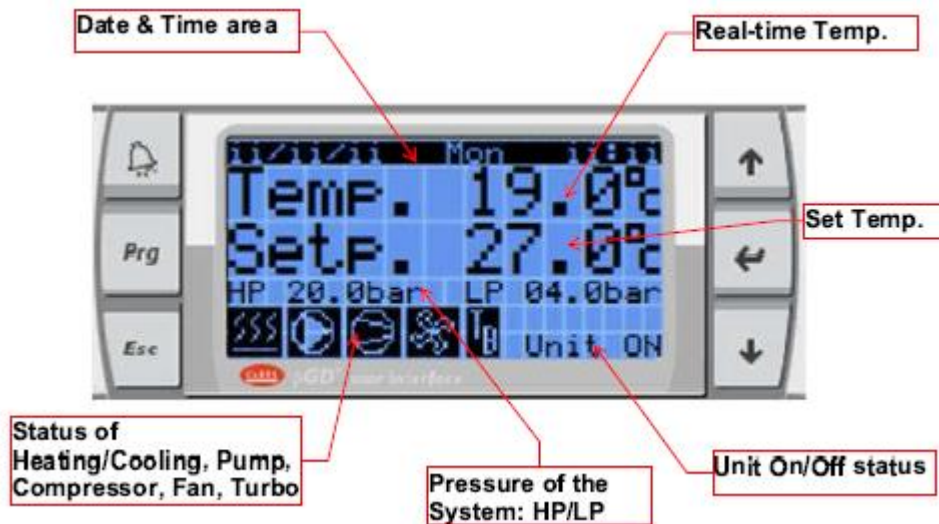



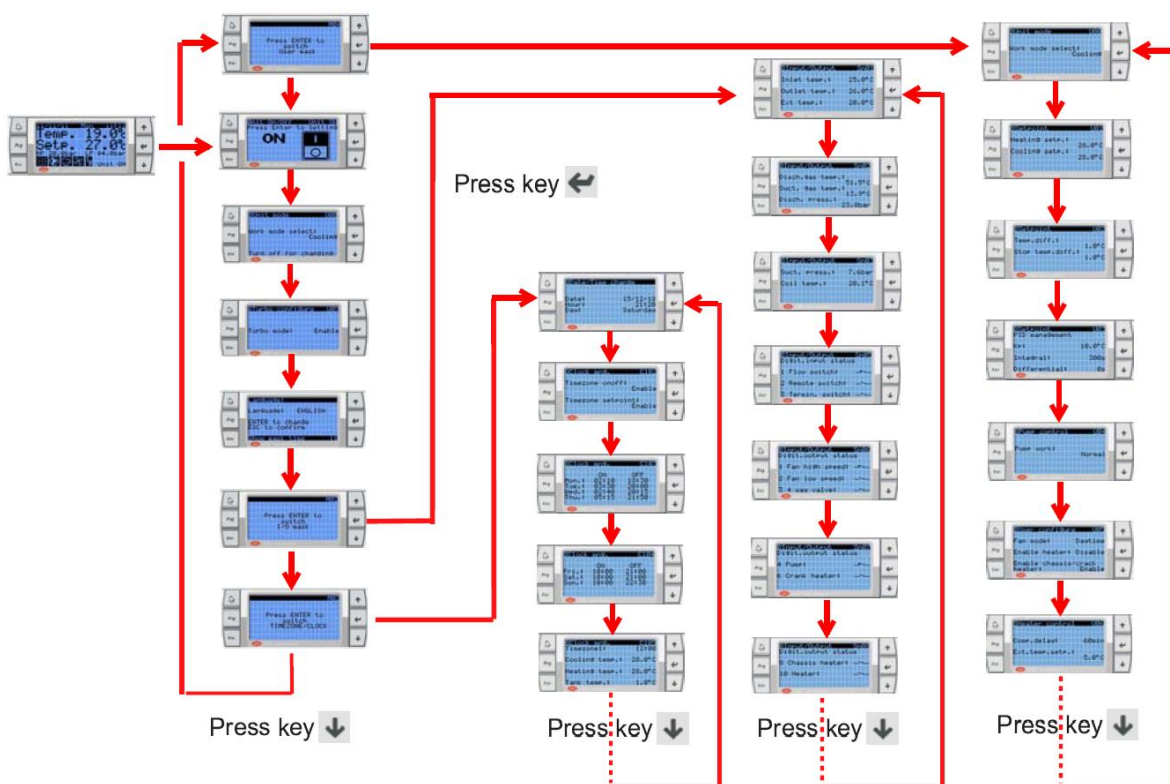

3.3 Structure of Interface Display

Press key to enter next stage interlace, press key to next mask in same stage.



3.4 The Main Masks of Controller

This is the main screen when the unit is power on. Parameters setting by pressing keys    

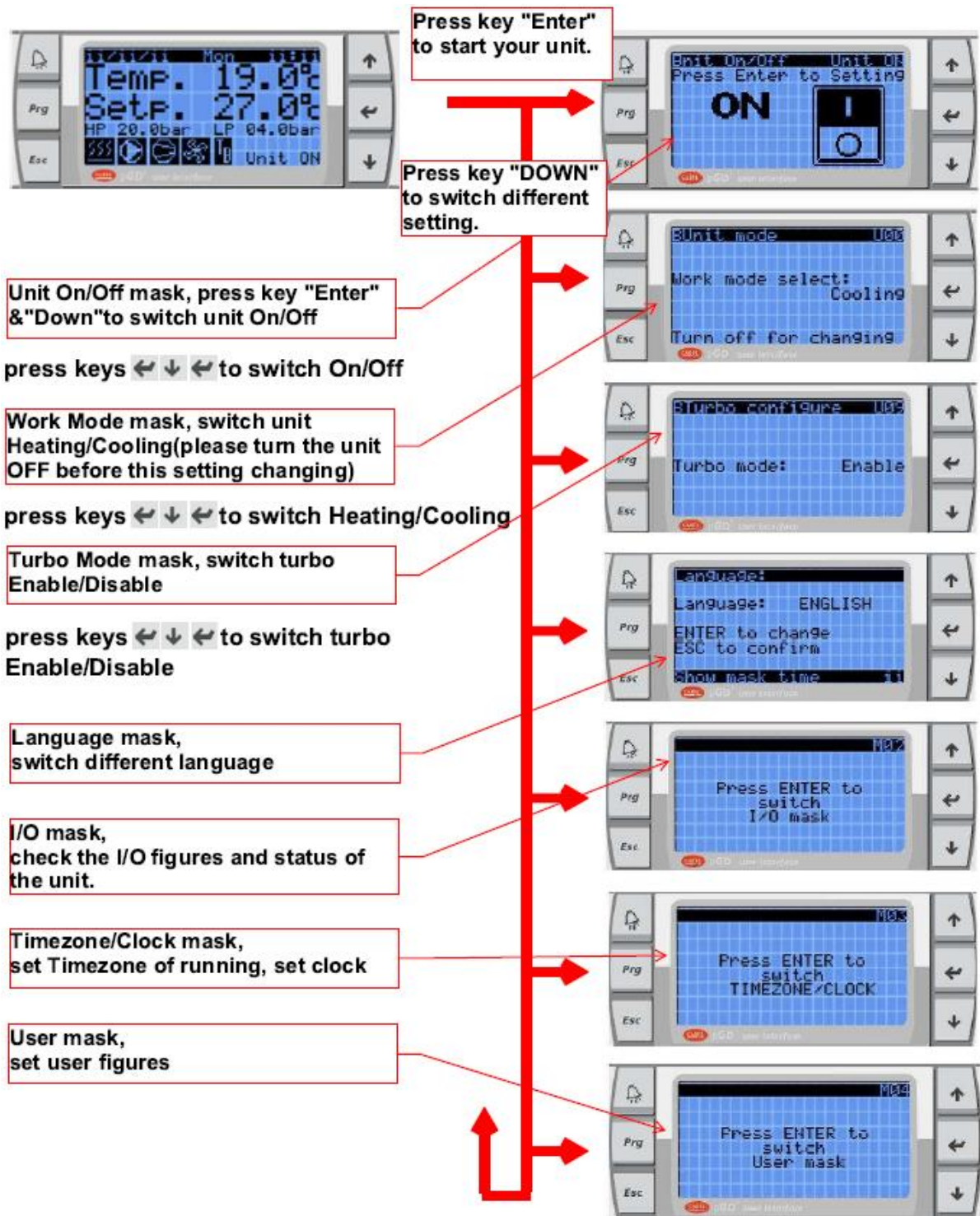

3.5 Unit On/Off

You can turn the unit On/Off in Unit On Off mask page.

Press key  then

Press key    to turn the unit ON/OFF

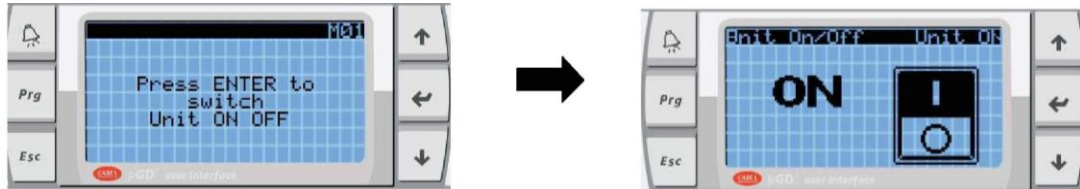



3.6 Temperature Setting

You can set the temperature in this main mask by pressing key  



3.7 Work Mode Changing (Heating/Cooling)

You can change the Heating/Cooling work mode by pressing key   

Please turn the unit OFF before you do this setting changing.



3.8 Turbo Mode Changing

You can Enable or Disable the Turbo mode by pressing key   



"TB" is shown if turbo mode is on

3.9 Language setting

You can change different language by pressing key  press key "Esc" to exit this page



3.10 I/O Mask (figures & status checking)

You can check the figures and status of the unit by pressing key 
Figures and status might be different if model or settings different.

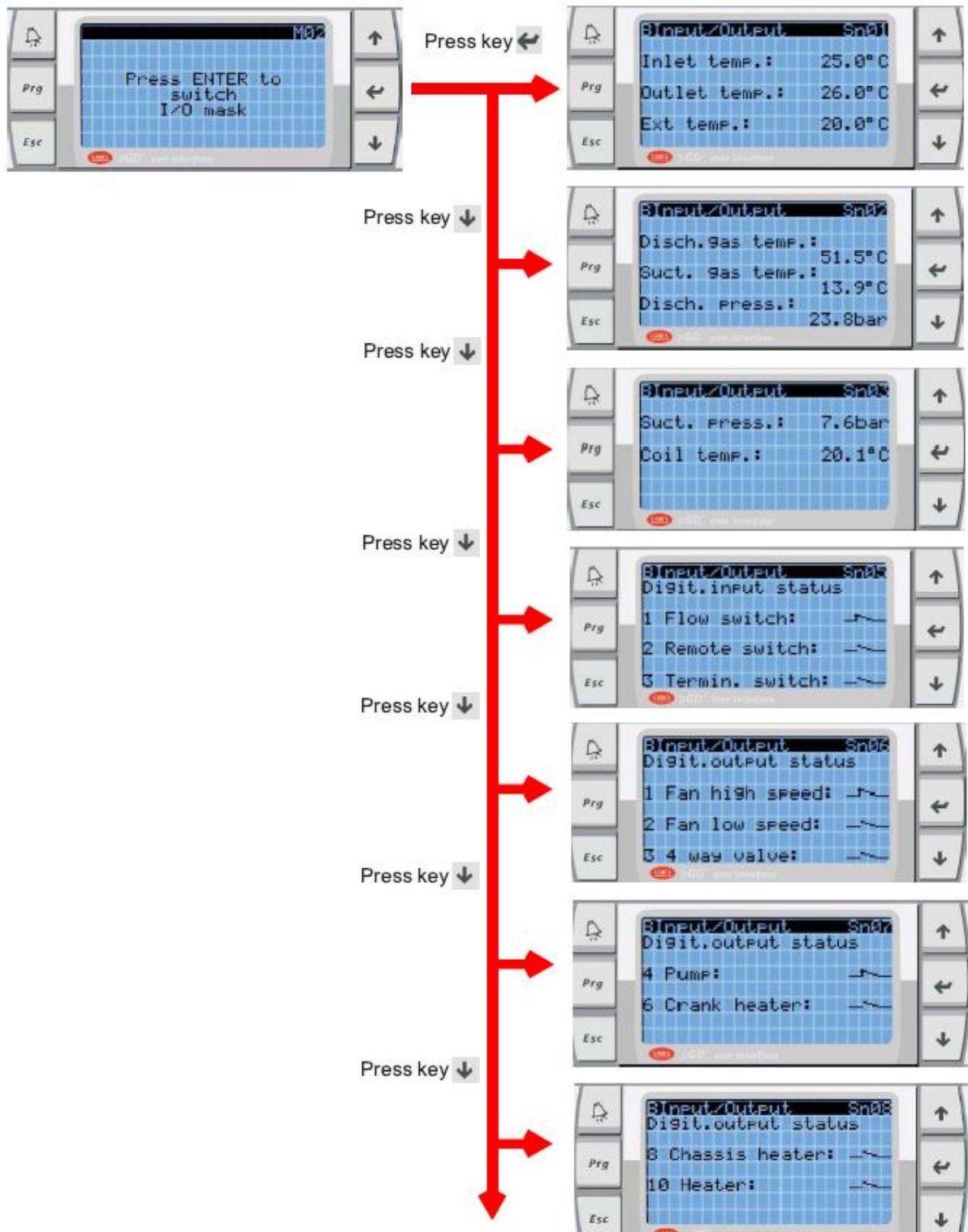

Keep pressing key 

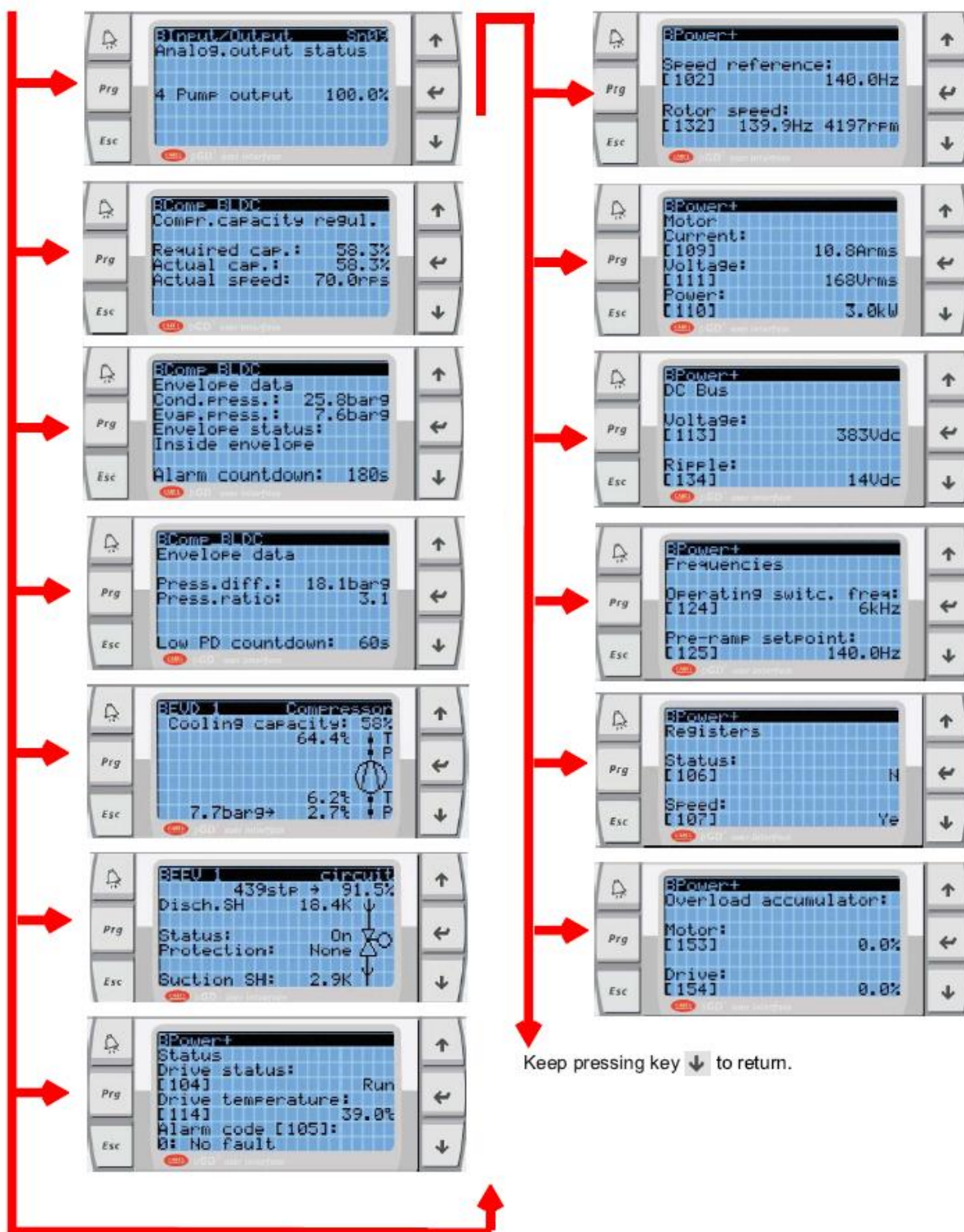

3.11 Timezone /Clock setting

You can set the Date, Clock and Timezone of unit running.

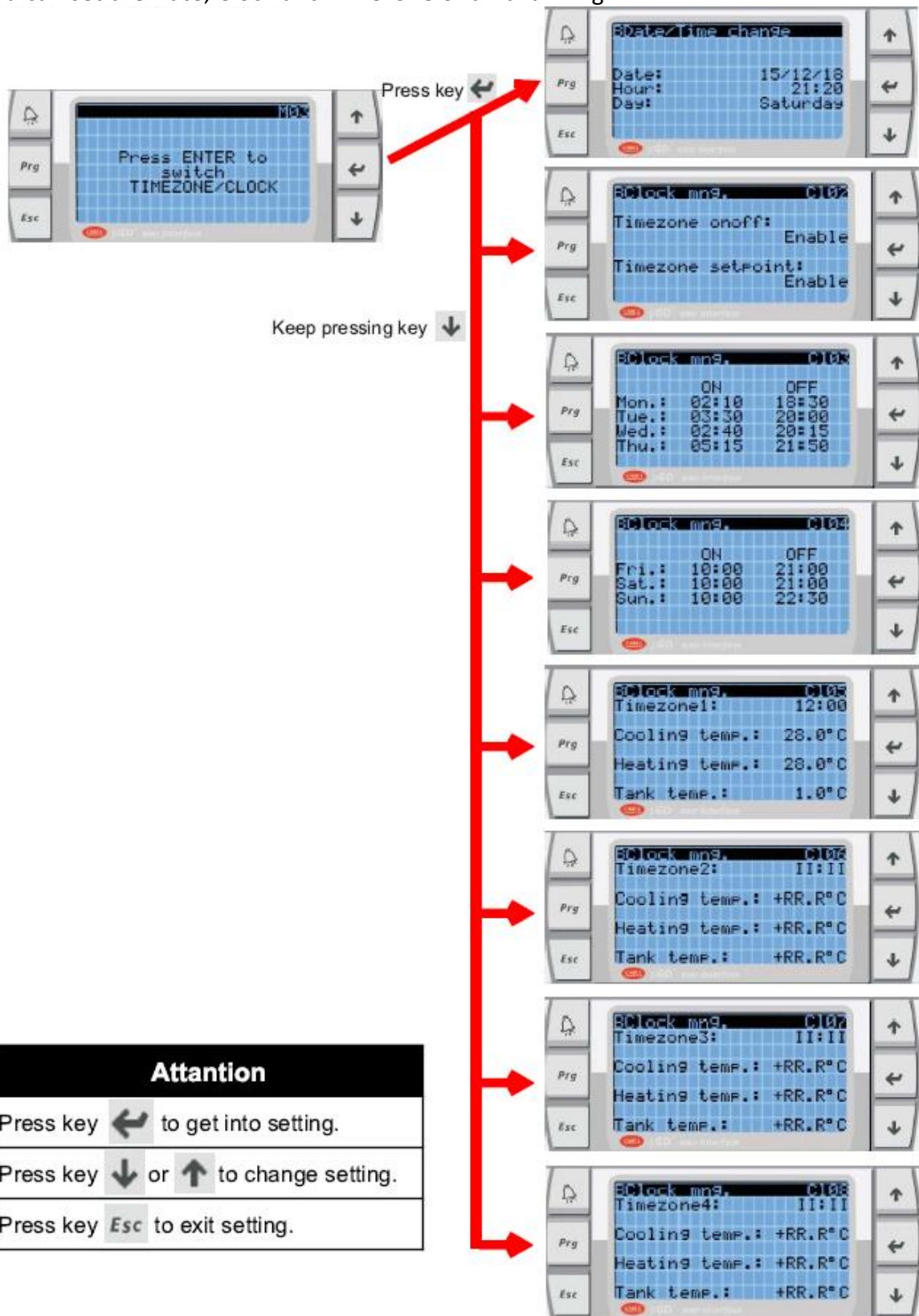

Attantion	
Press key	↩ to get into setting.
Press key	↓ or ↑ to change setting.
Press key	Esc to exit setting.

3.12 User Figures Setting

You can set the user figures after go into this setting page.

Press key to get into setting.

Keep pressing key

Work Mode mask, switch unit Heating/Cooling (please turn the unit OFF before this setting changing)

Setting Temp. of Heating/Cooling

Temp. different of unit Restart/Stop (for professional technician only)

Figures setting of PID parameters (for professional technician only)

Water Pump running mode setting (for professional technician only)

Fan running mode setting Electrical Heater Enable/Disable Chassis/Crack Heater Enable/Disable (for professional technician only)

Time figure of Heater about compressor delay. Ext. Temp. set point of Heater. (for professional technician only)

Delta Temp. setting (for professional technician only)

Keep pressing key

Unit auto start setting Enable/Disable

Attention	
Press key	to get into setting.
Press key or	to change setting.
Press key Esc	to exit setting.

3.13 Professional Program Setting (for professional technician only)

You can set the professional figures with Login Password.

Call your technical support to find the password.

Press key **Prg** to start program setting.



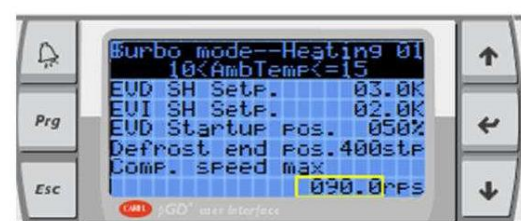

Attantion	
Press key ←	to get into setting.
Press key ↓ or ↑	to change setting.
Press key Esc	to exit setting.

You can set the advanced parameters of the unit (it need password to login).



3.14 Alarm Checking

You can check the alarm details by pressing key 

Press key  to check the alarm details



Press key  to check the alarm details one by one.



Press key  and hold 3 seconds to reset all alarms.



All alarms history is cleaned.

4. MAINTENANCE

General Recommendations

1. Check the water supply circulation system regularly for water leakage and air entering into the system, as the performance and reliability of the unit will be reduced.
2. Clean the pool water and filtration media regularly to maximize the performance and to prevent damage to the heat pump.
3. Regularly check all the panels and screws are securely attached.

Restore water flow to the heat pump, open the valves at the bypass kit and make sure filter pump is ON.

Disposal and Decommissioning

Collecting recyclable material, both those used for packaging (cardboard, nylon, etc.) and those replaced during routine and major maintenance is recommended. Suitable collection of waste material for recycling, processing and environmentally compatible disposal contributes in avoiding possible negative effects on the environment, health and promotes the reuse and/or recycling of device materials. Incorrect product disposal by the user may be punishable by current national laws.

When the unit reaches the end of its working life and must be removed and/or replaced, follow the instructions below:

1. Refrigerant gas must be collected by specialized technicians and sent to collection centers.
2. Compressor lubricant oil must be collected by specialized technicians and sent to collection centers.
3. The housing and other parts, if unusable, should be dismantled and divided according to their material type (for example, copper, aluminium, plastic, etc.) and must be sent to collection centers.

Winterizing

Failure to winterize could cause damage to the heat pump and void the warranty.

1. Turn of the heat pump and unplug the power cable from the main electrical outlet. Or turn of the electrical power at the main circuit breaker panel.
2. Shut of the water supply (bypass kit) to the heat pump.
3. Disconnect the IN and OUT water connections and drain out all the water from the heat pump. Use air to blow out any standing water inside the unit.
4. Reconnect the IN and OUT connections loosely to prevent debris entering the water connections.
5. Drain out all the water at the bottom of the heat pump panel.
6. Protect the heat pump from dirt accumulation. Do not wrap the heat pump with plastic or other material that can hold heat and/or humidity inside the device. Use the included protective cover.

Spring Startup

If the heat pump has been winterized, perform the following steps when starting the system in the spring:

1. Remove the protective cover and inspect the unit for any debris or structural problems.
2. Tighten the IN and OUT water connections securely.
3. Check the pool water chemical is balanced, see "Pool Water Chemistry" section.
4. Restore water flow to the heat pump, open the valves at the bypass kit and make sure filter pump is ON.
5. Restore electrical power to the heat pump and test the RCD.

POOL WATER CHEMISTRY

Special care must be taken to keep your pool water chemical balanced within the following limits:

Preferred Water Chemistry Reading			
	Minimum	Ideal	Maximum
Free Chlorine	0	0.5 - 3.0 ppm	5.0 ppm
Combined Chlorine	0	0 ppm	0.2 ppm
pH	7.2	7.4-7.6	7.8
Total Alkalinity	40 ppm	80 ppm	120 ppm
Calcium Hardness	50 ppm	100-250 ppm	350 ppm
Stabilizer (Cyanuric Acid)	10 ppm	20 - 40 ppm	50 ppm

If the concentration of one or more of the above readings becomes too high, irrevocable damage to your heat pump may occur. Failure to keep the pool water chemical between the limits will void the warranty.

Consult with your local swimming pool dealer for water treatment recommendation.

5. Troubleshooting

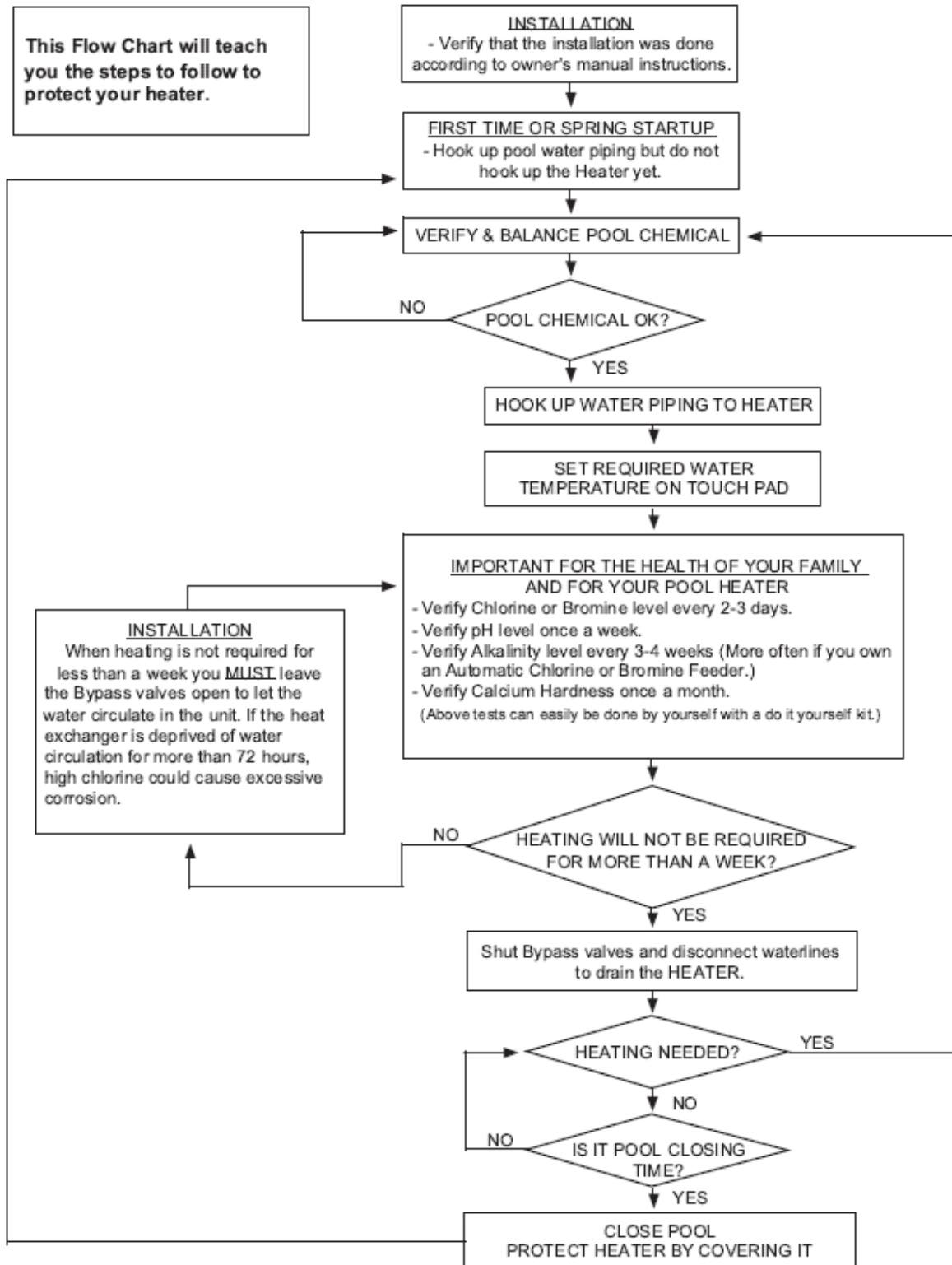

Fault	Cause	Solution
The appliance doesn't start	1. No power supply.	Check the power supply.
	2. The fuse on the gas side control board has tripped or the switch is open.	Verify that the circuit is not open and that it is properly grounded. Replace the fuse and reset the switch. Check that the circuit is stable and that the connections are well done.
	3. Some protection has intervened.	Identify the protection intervened, restore it and restart the appliance.
	4. Slow wiring.	Check the electrical wiring and tighten the connections.
	5. Compressor broken.	Replace the compressor.
The fan doesn't work	1. Wiring motor not connected.	Check the wiring motor.
	2. Fan motor fault.	Replace the fan motor.
Low heating performance	1. The plate heat exchanger is dirty.	Clean the plate heat exchanger.
	2. Ventilation is insufficient.	Remove the objects that prevent air circulation.
	3. Insufficient refrigerant.	Check that there are no leaks in the appliance and system, if necessary, repair them. Replace the refrigerant with new product
	4. Temperature out of range	Check that the setpoint temperature is not too high in heating or
Abnormal noise from the pump or no water circulation while the pump is running	1. Water loss in the circuit.	Check the filling tap, fill the circuit with the right amount of water.
	2. Air in the hydraulic circuit.	Remove air from the circuit.
	3. The valves in the hydraulic circuit are not fully open.	Verify that all valves are fully open.
	4. The water filter is dirty or clogged.	Clean the filter or replace it.
Compressor discharge pressure too high	1. Too much refrigerant.	Replace the refrigerant with new product and correct quantity.
	2. Air in the refrigerant circuit.	Replace the refrigerant with new product and correct quantity.
	3. Inadequate water flow.	Check the water flow in the circuit, if necessary, use a more performing pump.
	4. Too high Temperature	Make sure that the water supply temperature sensor works properly.
Suction pressure too low	1. Dirty filter drier.	Replace the filter drier.
	2. Electronic expansion valve blocked.	Repair or replace it.
	3. Loss of refrigerant.	Check that there are no leaks in the appliance and in the system, if necessary, repair them. Replace the refrigerant with new product and in the correct quantity.
The appliance does not complete the defrost cycle	1. Expansion battery sensor fault.	Check the position and value of the temperature sensor, if necessary, replace it.
	2. Ventilation is insufficient.	Eliminate objects that prevent air circulation. If necessary, clean the evaporation battery.

6. ALARM CODE LIST

Alarm Code	Description		Possible Cause	Solution
AL01	Too many mem writings		Program is over writing	Reset the unit and alarm, clean the old version program.
AL02	Retain mem write error		Memory writing error	Reset the unit and alarm, update to a new version program and clean the old version program.
AL03	Inlet probe error		Water inlet temp. sensor fail or loose connection	Check the wire connection or replace a new sensor
AL04	Outlet probe error		Water outlet temp. sensor fail or loose connection	Check the wire connection or replace a new sensor
AL05	Ambient probe error		Ambient temp. sensor fails or loose connection	Check the wire connection or replace a new sensor
AL06	Condenser coil temp		Condenser coil temp. sensor fail or loose connection	Check the wire connection or replace a new sensor
AL07	Water flow switch		Water flow sensor fail or loose connection	Check the water flow volume is big enough or not, check flow switch sensor wire connection
AL08	Phase sequ.prot.alarm		Phase wrong or phase lost	Check the power input wiring
AL09	Unit work hour warning		The unit over running time	Contact your technical support
AL10	Pump work hour warning		The water pump over running time	Contact your technical support
AL11	Comp.work hour warning		The compressor over running time	Contact your technical support
AL12	Cond.fan work hourWarn		The condenser fan motor over running time	Contact your technical support
AL13	Low superheat - Vlv.A		Superheat of EEV1 is too low	Contact your technical support
AL14	Low superheat - Vlv.B		Superheat of EEV2 is too low	Contact your technical support
AL15	LOP - Vlv.A		EEV1 LOP alarm	Contact your technical support
AL16	LOP - Vlv.B		EEV2 LOP alarm	Contact your technical support
AL17	MOP - Vlv.A		EEV1 MOP alarm	Contact your technical support
AL18	MOP - Vlv.B		EEV2 MOP alarm	Contact your technical support
AL19	Motor error - Vlv.A		Motor of EEV1 alarm	Contact your technical support
AL20	Motor error - Vlv.B		Motor of EEV2 alarm	Contact your technical support
AL21	Low suct.temp. - Vlv.A		Low suction temp. alarm for EEV1	Contact your technical support
AL22	Low suct.temp. - Vlv.B		Low suction temp. alarm for EEV2	Contact your technical support
AL23	High condens.temp.EVD		High condenser temp. alarm for EEV	Contact your technical support
AL35	BLDC-alarm:		Pressure different too much when start	Contact your technical support
AL36	BLDC-alarm:		Compressor stop	Contact your technical support
AL37	BLDC-alarm:		Compressor run out of operating range	Contact your technical support
AL38	BLDC-alarm:		Compressor fail in start	Contact your technical support
AL39	BLDC-alarm:		Compressor fail in start	Contact your technical support
AL40	BLDC-alarm:		Pressure different too low when running	Contact your technical support
AL41	BLDC-alarm:		Discharge temp. is too high	Contact your technical support
AL51	Power+ alarm:	Overcurrent	The drive has detected a current supplied that is too high due to: - sudden strong load increase; - acceleration that is too high; - wrong parameters values or inadequate motor.	Check the load, the dimension of the motor and the cables. Decrease acceleration, check the motor parameters.
AL52	Power+ alarm:	Motor overload	The current supplied has exceeded the motor rated current over the maximum time accepted	Check the load, the dimension of the motor and the cables. Check the motor parameters.
AL53	Power+ alarm:	Overvoltage	The DC voltage of the intermediate circuit has exceeded the limits envisioned due to: - deceleration that is too high; - high over-voltage peaks on the power supply network	Decrease deceleration.

Alarm Code	Description		Possible Cause	Solution
AL54	Power+ alarm:	Undervoltage	The DC voltage of the intermediate circuit is below the limits envisioned due to: - insufficient power supply voltage; - fault inside the drive.	In the event of temporary cut-off of the power supply, reset the alarm and re-start the drive. Check the power supply voltage.
AL55	Power+ alarm:	Drive over temperature	The temperature inside the drive has exceeded the maximum level allowed.	Check that the quantity and flow of cooling air are regular. Check that there is not dust in the heat sink. Check the environment temperature. Ensure that the switching frequency is not too high with respect to the environment temperature and the motor la
AL56	Power+ alarm:	Drive under temperature	The temperature of the drive is inferior to the minimum level allowed.	Warm up the ambient where the drive is installed.
AL57	Power+ alarm:	Overcurrent HW	The drive has detected an instantaneous current supplied that is too high due to: - sudden strong load increase; - motor cables short circuit; - wrong parameters values or inadequate motor.	Check the load, the dimension of the motor and the cables. Check the motor parameters.
AL58	Power+ alarm:	Reserved		
AL59	Power+ alarm:	Reserved		
AL60	Power+ alarm:	CPU error	Loss of data in memory	Reset alarm. In case of persistence call for assistance
AL61	Power+ alarm:	Parameter default	Execution of reset parameter default command; Parameters user setting corrupted	Set parameters again
AL62	Power+ alarm:	DC bus ripple	Input power supply phase loss	Check the input power supply phases to the drive
AL63	Power+ alarm:	Data communication fault	Data reception failure	Check the serial connection. Switch the drive off and back on again. In case of persistence call for assistance.
AL64	Power+ alarm:	Drive thermistor fault	Internal fault	Reset alarm. In case of persistence call for assistance
AL65	Power+ alarm:	Reserved		
AL66	Power+ alarm:	Reserved		
AL67	Power+ alarm:	Motor phase fault (**)	Motor cable disconnected	Check the connections of the motor cable
AL68	Power+ alarm:	Reserved (for future use)		
AL69	Power+ alarm:	Speed fault	Wrong parameters values or unsuited load	Switch the drive off and back on again and check the parameters are properly set. Check the motor load.
AL70	Power+ alarm:	PFC module error	PFC overcurrent	Reset alarm. In case of persistence call for assistance
AL71	Power+ alarm:	Power supply overvoltage	Too high AC power supply voltage	Check input power supply and if inductive load generating overvoltage are connected to the line
AL72	Power+ alarm:	Power supply undervoltage	Too low AC power supply voltage	Check input power supply
AL73	Power+ alarm:	Reserved		
AL74	Power+ alarm:	Reserved		
AL75	Power+ alarm:	Ground fault	The drive has detected a ground current too high	Check ground insulation of the motor and wires
AL76	Power+ alarm:	CPU sync error	Overload CPU	Reset alarm. In case of persistence call for assistance
AL77	Power+ alarm:	CPU sync error 2	Loss of data in memory	Reset alarm. In case of persistence call for assistance
AL78	Power+ alarm:	Drive overload	The current supplied has exceeded the drive rated current over the maximum time accepted	Check the load, the dimension of the motor and the cables. Check the motor parameters.

Alarm Code	Description		Possible Cause	Solution
AL79	Power+ alarm:	Safety intervention		
AL114	Power+ alarm:		Drive connection alarm	Check the wiring connection between Power Drive and controller
AL115	EEV alarm:		Superheat of EEV is too low	Contact your technical support
AL116	EEV alarm:		EEV LOP alarm	Contact your technical support
AL117	EEV alarm:		EEV MOP alarm	Contact your technical support
AL118	EEV alarm:		High condenser temp. alarm for EEV	Contact your technical support
AL119	EEV alarm:		Low suction temp. alarm for EEV	Contact your technical support
AL120	EEV alarm:		Motor of EEV alarm	Contact your technical support
AL121	EEV alarm:		PID of EEV alarm	Contact your technical support
AL122	EEV alarm:		EEV Emergency stop alarm	Contact your technical support
AL123	EEV alarm:		EEV temp. different protection	Contact your technical support
AL124	EEV alarm:		EEV pressure different protection	Contact your technical support
AL125	EEV alarm:		EEV range error	Contact your technical support
AL126	EEV alarm:		EEV position error	Contact your technical support
AL127	EEV alarm:		EEV serial No. error	Contact your technical support
AL128	Low press alarm		Low pressure protection	Check refrigerant is enough or not
AL129	High press alarm		High pressure protection	Check water volume is enough or not, check water or air temp. is high or not
AL130	Disc.temp.probe error		Discharge temp. sensor fail or loose connection	Check discharge temp. check the wire connection or replace a new sensor
AL131	Suct.temp.probe error		Suction temp. sensor fail or loose connection	Check suction temp. check the wire connection or replace a new sensor
AL132	Disc.press.probe error		Discharge pressure sensor fail	Check the running pressure, increase the water volume or decrease the setting temp.
AL133	Suct.press.probe error		Discharge pressure sensor fail	Check the running pressure, the refrigerant is enough or not.
AL134	Tank temp.probe error		Water tank temp. sensor fail or loose connection	Check water tank temp. check the wire connection or replace a new sensor
AL135	EVI SuctT.probe error		EVI suction temp. sensor alarm	Check EVI suction temp. check the wire connection or replace a new sensor
AL136	EVI SuctP.probe error		EVI suction pressure sensor alarm	Check EVI suction pressure, check the wire connection or replace a new sensor
AL137	Flow switch alarm		Water flow sensor fail or loose connection	Check the water flow volume is big enough or not, check flow switch sensor wire connection
AL138	High temp. alarm		Water outlet temp. is too high	Check the water flow volume is big enough or not, decrease the setting temp.
AL139	Low temp. alarm		Water outlet temp. is too low	Check the water flow volume is big enough or not, increase the setting temp.
AL140	Temp.delta alarm		Temp. different is too much between water inlet and outlet	Check the water flow volume is big enough or not
AL152	Power freq.alarm		Frequency of power supply is unstable	Stop and check the power supply

7. DIAGRAMS

7.1 Wiring Diagram

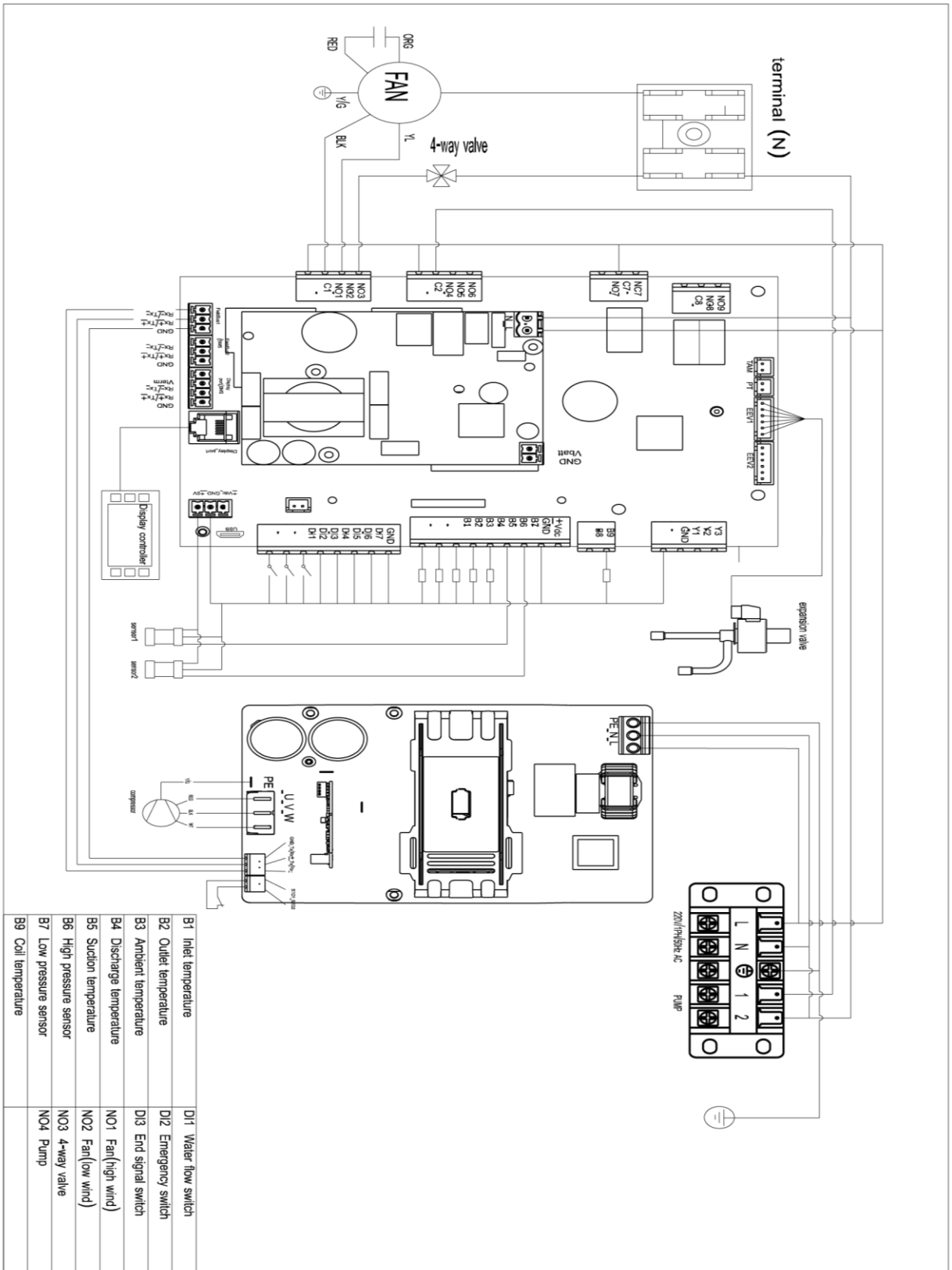

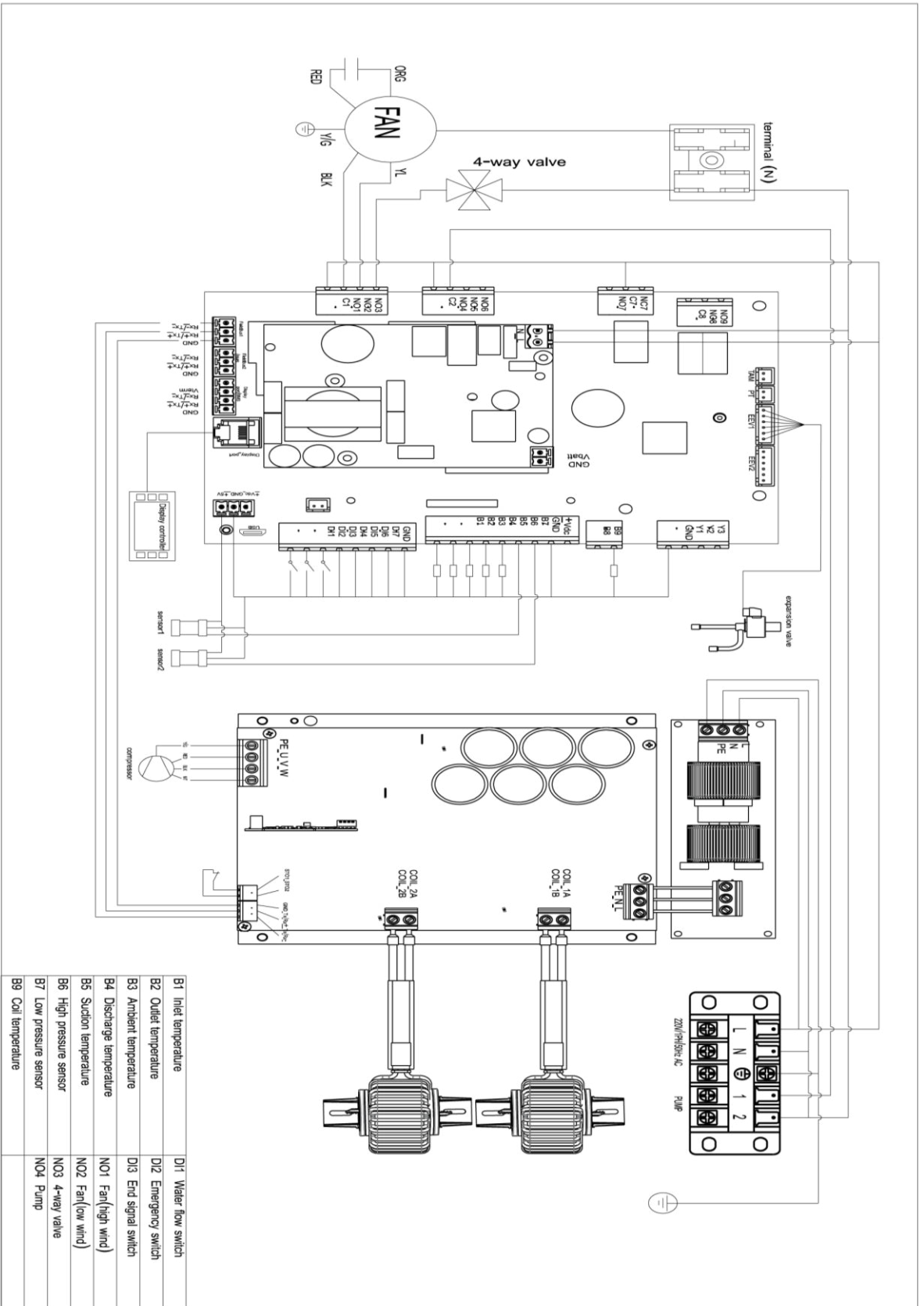

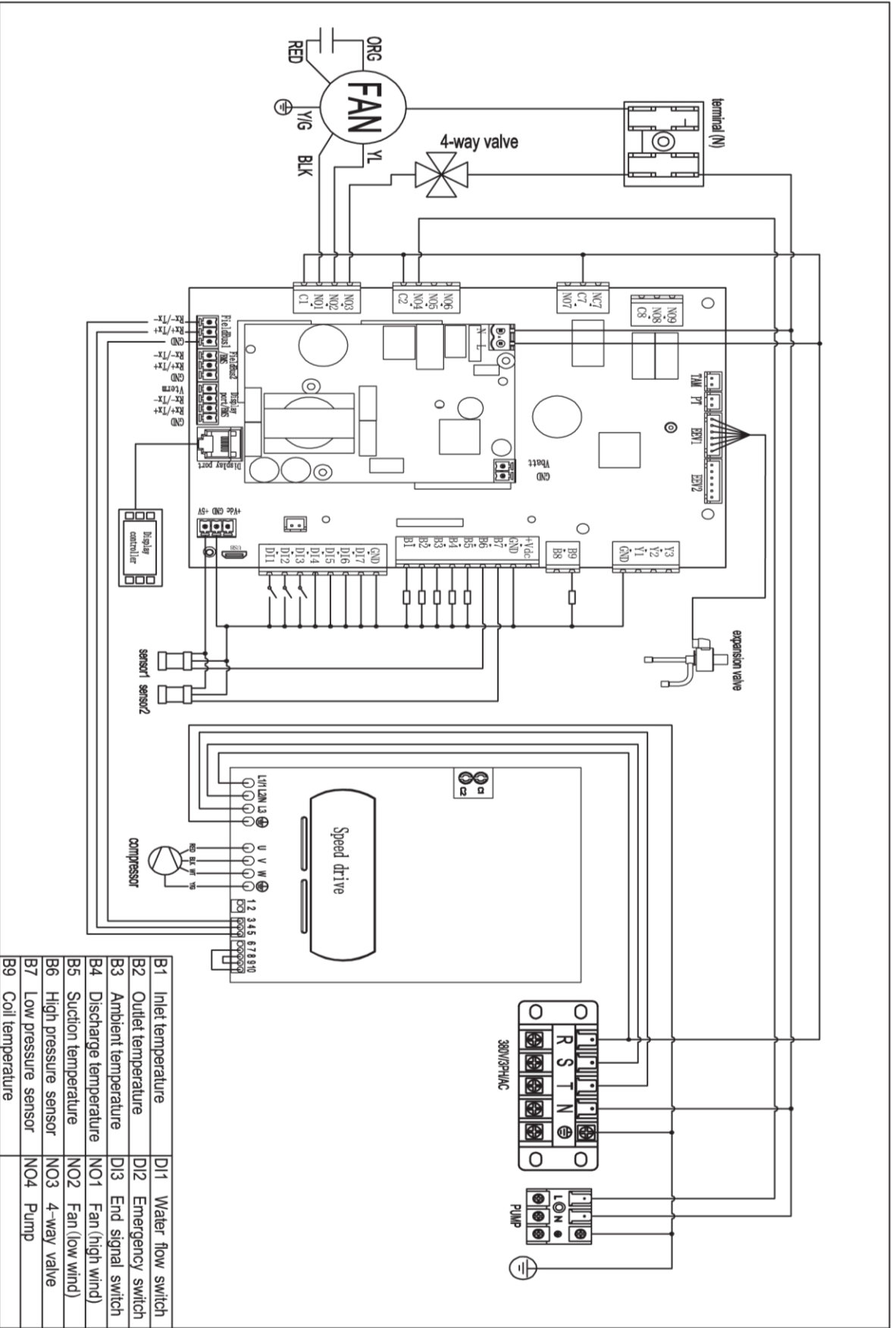

B1	Inlet temperature	D11	Water flow switch
B2	Outlet temperature	D12	Emergency switch
B3	Ambient temperature	D13	End signal switch
B4	Discharge temperature	N01	Fan (high wind)
B5	Suction temperature	N02	Fan (low wind)
B6	High pressure sensor	N03	4-way valve
B7	Low pressure sensor	N04	Pump
B9	Coil temperature		

7.2 Explosion Diagram

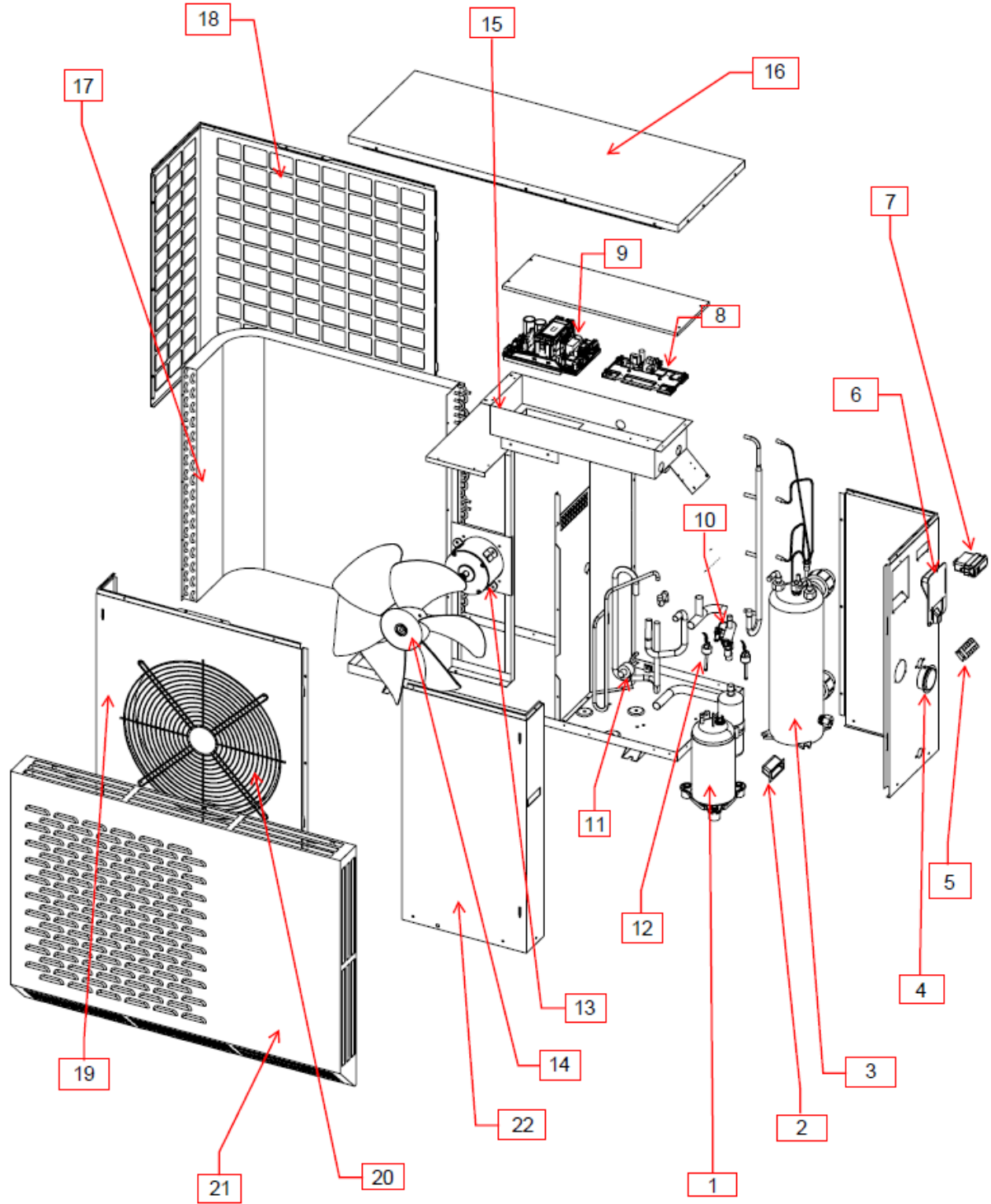

8. TERMS OF THE WARRANTY

As original purchaser of this equipment have purchased from Emaux Water Technology Co Ltd, through Authorized International Distributor or Dealer, warrants its products free from defects in materials and workmanship under normal use during warranty period. The warranty period begins on the day of purchase and

extends only to the original purchaser. It is not transferable to anyone who subsequently purchases the product

from you. It excludes all expendable parts.

During the warranty period, Emaux authorized reseller will repair or replace defective parts with new parts or, at

the option of Emaux, serviceable used parts that are equivalent or superior to new parts in performance.

This Limited Warranty extends only to products purchased from Emaux authorized reseller. This Limited Warranty does not extend to any product that has been damaged or rendered defective

(a) as a result of accident, misuse or abuse;

(b) as a result of an act of God;

(c) by operation outside the usage parameters stated herein;

(d) by the use of parts not manufactured or sold by Emaux;

(e) by modification of the product;

(f) as a result of war or terrorist attack; or

(g) as a result of service by anyone other than Emaux authorized reseller or authorized agent.

EXCEPT AS EXPRESSLY SET FORTH IN THIS WARRANTY, EMAUX MAKES NO OTHER WARRANTIES EXPRESSED OR

IMPLIED, INCLUDING ANY IMPLIED WARRANTIES OR MERCHANTABILITY AND FITNESS FOR A PARTICULAR

PURPOSE. EMAUX EXPRESSLY DISCLAIMS ALL WARRANTIES NOT STATED IN THIS LIMITED WARRANTY. ANY

IMPLIED WARRANTIES THAT MAY BE IMPOSED BY LAW ARE LIMITED TO THE TERMS OF THIS EXPRESS LIMITED

WARRANTY.