

Star Swimming pool



Single-stage centrifugal pump for water recirculation and filtering

Applications

Recirculation and filtering of water of large pools.

Equipment

No cable, no plug.

Materials

Pump body and prefilter in cast iron. Filter and shaft in stainless steel AISI 304. Impeller in SS 304. Mechanical seal. Motor casing in aluminium.

Motor

Closed, with external ventilation. IP 55 protection. Class F insulation.



Hydraulic performance table

Model	I [A]		P1 [kW]	P2		l/min	400	700	1000	1500	3000	Code
	3~230V	3~400V	3~	[kW]	[HP]		m ³ /h	25	40	55	90	
Star 30 65	8,1	4,6	2,85	2,2	3	mwc	17	15	10	-	-	205412
Star 40 65	10,7	6,1	3,9	3	4		19	18	14	-	-	205413
Star 55 80	14	8	4,9	4	5,5		20	18	16	13	-	205414
Star 75 80	19	10,9	6,7	5,5	7,5		20	19	18	15	-	205415
Star 100 80	25,6	14,7	9,1	7,5	10		27	25	24	21	-	205416
Star 150 100	36,6	20,9	12,9	11	15		27	27	27	27	17	205417

Dimensions and weights

Model	L	A	M1	W	B	N1	H1	H2	H3	Kg
Star 30 65	799	510	70	280	265	190	132	160	156	77
Star 40 65	799	510	70	280	265	190	132	160	156	79
Star 55 80	854	510	95	330	265	212	160	180	156	94
Star 75 80	854	510	95	330	265	212	160	180	156	103
Star 100 80	854	510	95	330	265	212	160	180	156	109
Star 150 100	1024	542	95	345	265	250	180	225	156	146

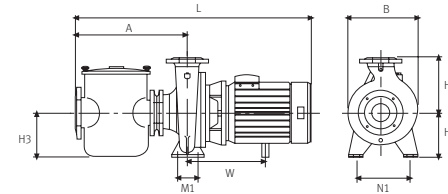

Performance curves at 2900rpm

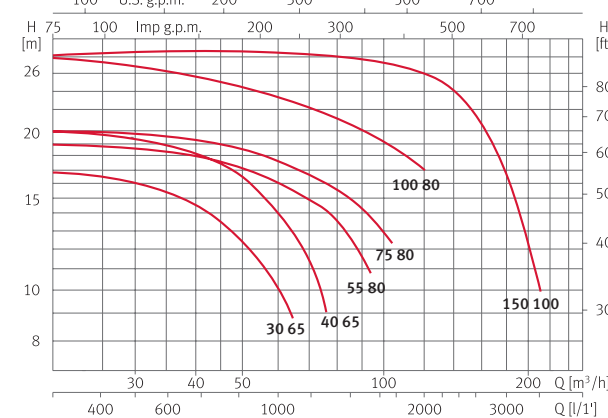

Nadorself Swimming pool



Single-stage centrifugal pump for water stream

Applications

Jet-stream in swimming pools. Generate a strong stream of water and transform swimming pools into places for sport and leisure. Self-priming up to 4m.

Motor

Asynchronous, 2 poles. IP 44 protection. Class F insulation. 1~: Thermal protection included. Continuous operation.

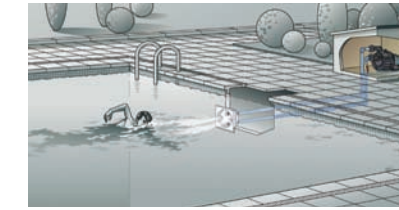

Materials

Pump body, impeller, seal mounting, diffuser and discharge in technopolymer. Suction in reinforced rubber. Pump shaft in AISI 431. Mechanical seal. Motor casing and support in aluminium. O-rings in NBR.

Limitations

Maximum water temperature: 40° C.

Equipment

Connection box V0 (self-extinguishing flame). P2 capacitor (10.000h). No cable, no plug.



Hydraulic performance table

Model	I [A]			P1 [kW]		P2		c [µF]	l/min	100	200	400	600	800	1000	1200	1300	Code	
	1~230V	3~230V	3~400V	1~	3~	[kW]	[HP]			m ³ /h	6,0	12	24	36	48	60	72	78	1~230V
Nadorself 200	10,2	6,7	4	2,2	2,2	1,5	2	40	mwc	12,9	12,2	10,6	8,5	6	-	-	-	203165	203167
Nadorself 300	13,4	8,6	5	3	3	2,3	3	60		14,6	14	12,8	11,3	9	6,5	-	-	203166	203168
Nadorself 400	-	11,8	6	-	3,4	3	4	-		17,2	16,6	15,3	13,8	11,6	9,4	6,3	4,5	-	203169

Performance curves at 2900 rpm

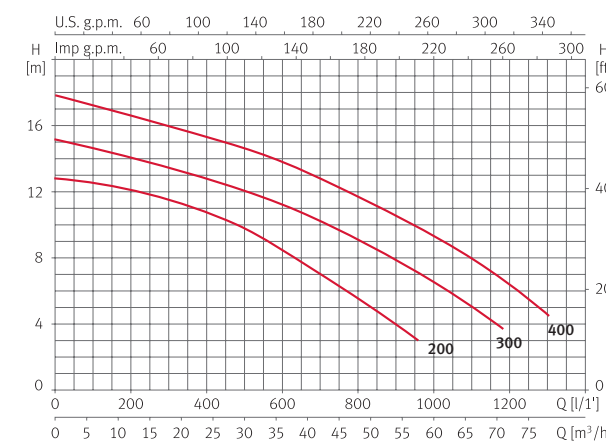

Dimensions and weights

Model	A	B	C	D	E	F	G	H	I	Kg
Nadorself 200	416	335	615	130	249	418,5	70	212 ^{mm}	46,5	25,1/23,1
Nadorself 300	416	335	615	130	249	418,5	70	212 ^{mm}	46,5	26,1/25,8
Nadorself 400	416	335	615	130	249	418,5	70	212 ^{mm}	46,5	28

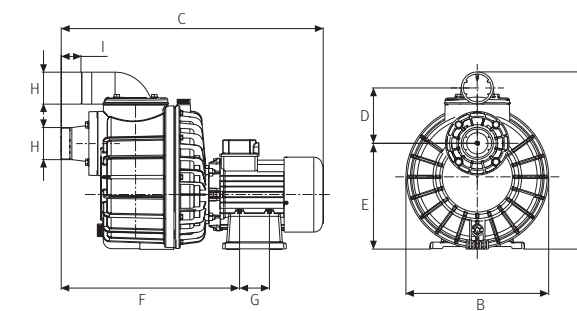

*Espa 2025 SL guarantees all its products against production defects for 2 years from the invoice date of the product. Warranty would not be considered if the product is damaged due external causes such as installation, misuse, poor maintenance, input supply outside of the operating range, damage due weather conditions or operation outside of predetermined conditions, components ordinary wear under normal operating conditions and damage caused by external agents.



*Espa 2025 SL guarantees all its products against production defects for 2 years from the invoice date of the product. Warranty would not be considered if the product is damaged due external causes such as installation, misuse, poor maintenance, input supply outside of the operating range, damage due weather conditions or operation outside of predetermined conditions, components ordinary wear under normal operating conditions and damage caused by external agents.



40/2 Soi.37/2, Kingkaew Road, Samutprakarn 10540, Thailand
Tel: 66 2 738 5088-99, 66 2 175 2561-65 Fax: 66 2 738 5299, 66 2 738 4209
Email: sales@poolspa.co.th, projects@poolspa.co.th Website: www.poolspa.co.th

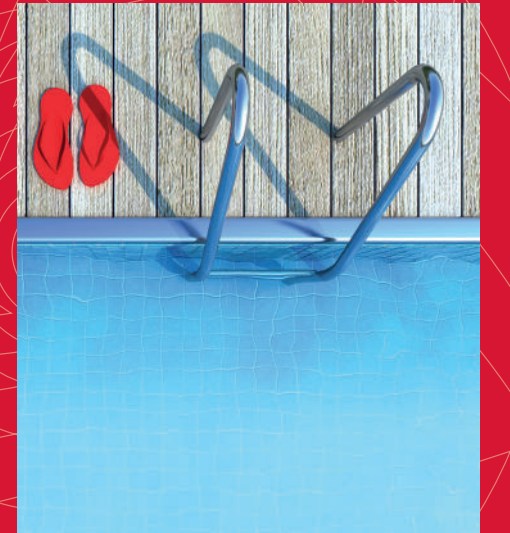

Swimming pool

Silen I Swimming pool



Single-stage centrifugal pump for water recirculation and filtering

Applications

Recirculation and filtering of water of small swimming pools.
Very quiet-running (LWA 70dB).
Self-priming up to 4m.

Motor

Asynchronous, 2 poles.
IP 55 protection.
Class F insulation.
Thermal protection included.
Continuous operation.

Materials

Pump body, foot, impeller, seal mounting, diffuser, suction and discharge in technopolymer.
Pump shaft in AISI 431.
ESPA mechanical seal.
Motor casing in aluminium.
O-rings in NBR.

Limitations

Maximum water temperature: 40° C.



Equipment

Connection box V0 (self-extinguishing flame).
P2 capacitor (10.000h).
No cable, no plug.
Metric unions included (50mm).

Request for imperial unions (1 1/2")

Hydraulic performance table

Model	I [A]		P1 [kW]		P2		c [µF]	*Pool volume [m³]	l/min	Q [m³/h]								Code
	1-230V	1~	[kW]	[HP]	1.5	3.0				4.5	6.0	9.0	12	15	17.4	1-230V		
Silen I 33	2	0,45	0,25	0,33	12	65			10,2	9,7	8,6	7,2	3,2	-	-	-	203144	
Silen I 50	2,8	0,65	0,37	0,5	12	75			12,3	11,9	11,3	10,5	8,1	4,6	-	-	203145	
Silen I 100	3,8	0,85	0,75	1	12	85			13,8	13,3	13	12,5	10,8	8,1	4,8	1,8	203146	

*Considering water circulation of 8 h/day

Dimensions and weights

Model	A	B	C	D	E	F	G	H	I	J	K	L	Kg
Silen I 33	439	192	115	304	210	2 1/4"	221	2 1/4"	264	Ø9	108	Ø212	8,9
Silen I 50	439	192	115	304	210	2 1/4"	221	2 1/4"	264	Ø9	108	Ø212	10,2
Silen I 100	439	192	115	304	210	2 1/4"	221	2 1/4"	264	Ø9	108	Ø212	10,9

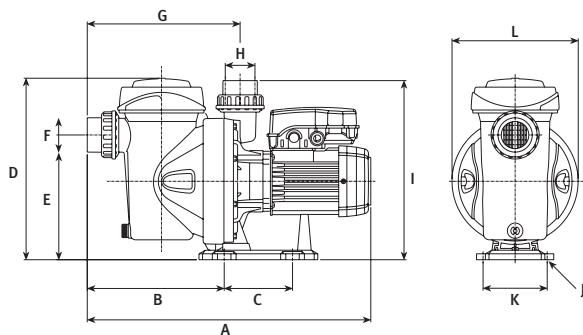

Performance curves at 2900 rpm

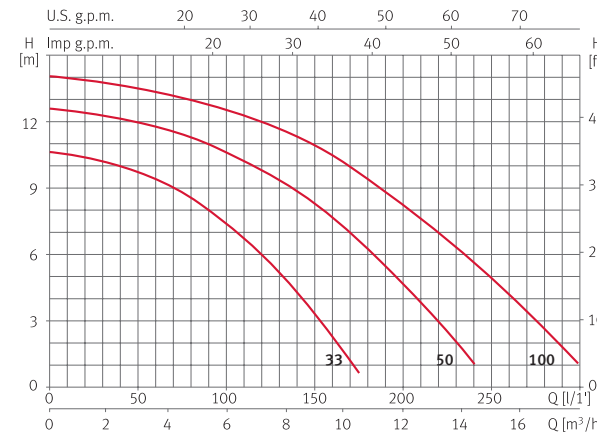

*Espa 2025 SL guarantees all its products against production defects for 2 years from the invoice date of the product. Warranty would not be considered if the product is damaged due external causes such as installation, misuse, poor maintenance, input supply outside of the operating range, damage due weather conditions or operation outside of predetermined conditions, components ordinary wear under normal operating conditions and damage caused by external agents.

Silen S Swimming pool



Single-stage centrifugal pump for water recirculation and filtering

Applications

Recirculation and filtering of water of medium swimming pools.
Very quiet-running (LWA 75dB).
Self-priming up to 4m.

Motor

Asynchronous, 2 poles.
IP 55 protection.
Class F insulation.
1~: Thermal protection included.
Continuous operation.

Materials

Pump body, foot, impeller, seal mounting, diffuser, suction and discharge in technopolymer.
Pump shaft in AISI 431.
ESPA mechanical seal.
Motor casing in aluminium.
O-rings in NBR.

Limitations

Maximum water temperature: 40° C.



Equipment

Connection box V0 (self-extinguishing flame).
P2 capacitor (10.000h).
No cable, no plug.
Metric unions included (suction 50/63mm, discharge 50mm).

Request for imperial unions (suction 1 1/2" / 2", discharge 1 1/2")

Hydraulic performance table

Model	I [A]			P1 [kW]		P2		c [µF]	*Pool volume [m³]	l/min	Q [m³/h]								Code	
	1-230V	3-230V	3-400V	1~	3~	[kW]	[HP]				40	80	120	160	215	265	325	400	1-230V	3-230V/400V
Silen S 60	3,7	2,4	1,4	0,8	0,8	0,44	0,6	16	90		13,6	13,2	12,6	10,9	6,7	-	-	-	203147	203151
Silen S 75	5,5	3,3	1,9	1,2	1,0	0,55	0,75	16	110		15,2	15	12,5	13,1	9,9	6	-	-	203148	203152
Silen S 100	6,0	3,8	2,2	1,4	1,2	0,75	1,0	16	125		16,9	16,5	16	15	12,9	10	5,9	-	203149	203153
Silen S 150	7,1	4,8	2,8	1,6	1,6	1,1	1,5	25	150		18,6	18,2	17,7	16,9	15,1	13	10	5,1	203150	203154

*Considering water circulation of 8 h/day

Dimensions and weights

Model	A	B	C	D	E	F	G	H	I	J	K	L	Kg
Silen S 60	495	211	170	225	2 1/4"	225	2 1/4"	308	159	Ø9	319	238	8,9
Silen S 75	495	211	170	225	2 1/4"	225	2 1/4"	308	159	Ø9	319	238	10,2
Silen S 100	495	211	170	225	2 1/4"	225	2 1/4"	308	159	Ø9	319	238	10,9
Silen S 150	495	211	170	225	2 1/4"	225	2 1/4"	308	159	Ø9	319	238	13,5

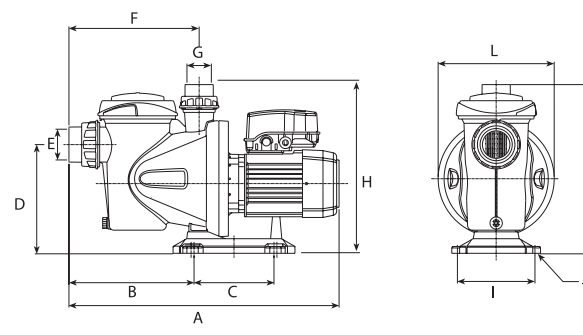

Performance curves at 2900 rpm

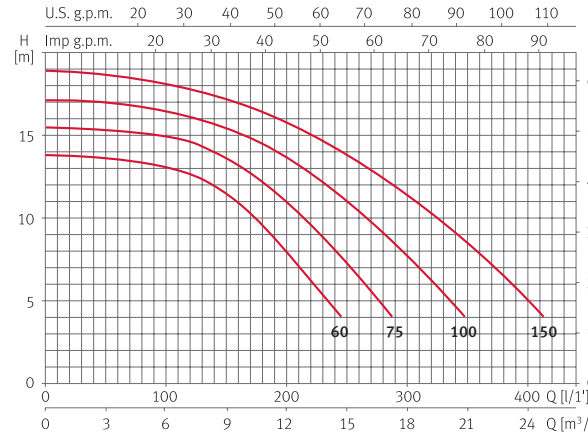

*Espa 2025 SL guarantees all its products against production defects for 2 years from the invoice date of the product. Warranty would not be considered if the product is damaged due external causes such as installation, misuse, poor maintenance, input supply outside of the operating range, damage due weather conditions or operation outside of predetermined conditions, components ordinary wear under normal operating conditions and damage caused by external agents.

Silen S2 Swimming pool



Single-stage centrifugal pump for water recirculation and filtering

Applications

Recirculation and filtering of water of large swimming pools.
Very quiet-running (LWA 80dB).
Self-priming up to 4m.

Motor

Asynchronous, 2 poles.
IP 55 protection.
Class F insulation.
1~: Thermal protection included.
Continuous operation.

Materials

Pump body, foot, impeller, seal mounting, diffuser, suction and discharge in technopolymer.
Pump shaft in AISI 431.
ESPA mechanical seal.
Motor casing in aluminium.
O-rings in NBR.

Limitations

Maximum water temperature: 40° C.



Equipment

Connection box V0 (self-extinguishing flame).
P2 capacitor (10.000h).
No cable, no plug.
Metric unions included (63mm).

Request for imperial unions (2")

Hydraulic performance table

Model	I [A]			P1 [kW]		P2		c [µF]	*Pool volume [m³]	l/min	Q [m³/h]								Code	
	1-230V	3-230V	3-400V	1~	3~	[kW]	[HP]				100	150	250	350	450	500	550	650	1-230V	3-230V/400V
Silen S2 75	4,5	3,8	2,2	1,0	1,0	0,55	0,75	25	110		13,2	12,8	10	5,5	-	-	-	-	203155	203160
Silen S2 100	7	4,8	2,8	1,5	1,6	0,92	1,25	25	150		16,5	16	14,2	10	4	-	-	-	203156	203161
Silen S2 150	8,5	5,3	3,1	1,9	1,9	1,1	1,5	25	180		18,5	18,2	16,5	13	8,2	5,5	-	-	203157	203162
Silen S2 200	9,7	6,5	3,8	2,2	2,2	1,5	2,0	30	200		19,5	19,1	18	15	11,1	9	6,3	-	203158	203163
Silen S2 300	12,5	8,6	5	2,8	2,6	2,2	3,0	60	240		21,5	21	19,9	18	14,9	12,9	10,3	5	203159	203164

*Considering water circulation of 8 h/day

Performance curves at 2900 rpm

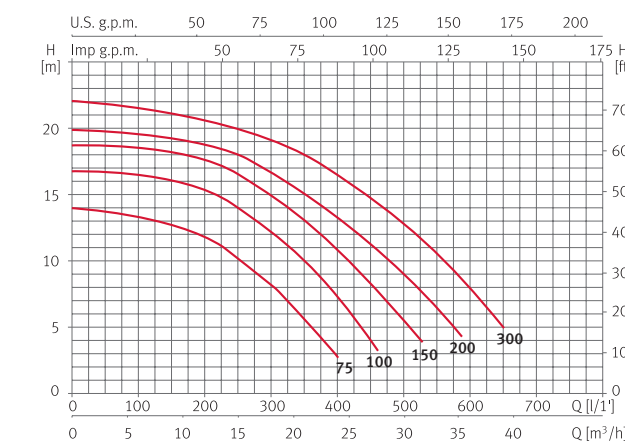

Dimensions and weights

Model	A	B	C	D	E	F	G	H	I	Kg
Silen S2 75	624	222	272	285	188	268	Ø13	2 3/4"	326,5	14
Silen S2 100	624	222	272	285	188	268	Ø13	2 3/4"	326,5	15
Silen S2 150	624	222	272	285	188	268	Ø13	2 3/4"	326,5	18
Silen S2 200	624	222	272	285	188	268	Ø13	2 3/4"	326,5	21
Silen S2 300	624	222	272	285	188	268	Ø13	2 3/4"	326,5	23

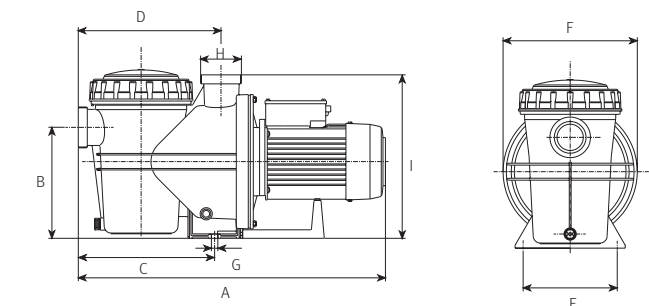

*Espa 2025 SL guarantees all its products against production defects for 2 years from the invoice date of the product. Warranty would not be considered if the product is damaged due external causes such as installation, misuse, poor maintenance, input supply outside of the operating range, damage due weather conditions or operation outside of predetermined conditions, components ordinary wear under normal operating conditions and damage caused by external agents.